



A KSB Company

SISTO-C HV, SISTO-C LAP
SISTO-C Accessories
SISTO-B

Operating Manual



Legal information/Copyright

Operating Manual

Original operating manual

All rights reserved. The contents provided herein must neither be distributed, copied, reproduced, edited or processed for any other purpose, nor otherwise transmitted, published or made available to a third party without the manufacturer's express written consent.

Subject to technical modification without prior notice.

© SISTO Armaturen S.A., Echternach, Luxemburg 2026-03-23

Contents

	Glossary	5
1	General	6
	1.1 Principles	6
	1.2 Contact data	6
	1.3 Target group	6
	1.4 Other applicable documentation.....	6
	1.5 Available software / web site	6
	1.6 Symbols	7
	1.7 Key to safety symbols/markings.....	7
2	Safety.....	8
	2.1 General.....	8
	2.2 Intended use	9
	2.2.1 Prevention of foreseeable misuse	9
	2.3 Personnel qualification and training	9
	2.4 Consequences and risks caused by non-compliance with this manual.....	9
	2.5 Safety awareness	10
	2.6 Safety information for the operator/user	10
	2.7 Safety information for maintenance, inspection and installation	10
	2.8 Unauthorised modes of operation	11
	2.9 Information on explosion protection.....	11
3	Transport/Storage/Disposal	13
	3.1 Checking the condition upon delivery.....	13
	3.2 Packaging.....	13
	3.3 Transport.....	13
	3.4 Storage/preservation.....	13
	3.5 Return to supplier.....	14
	3.6 Disposal.....	14
4	Description	16
	4.1 Product information	16
	4.1.1 Product information as per Regulation No 1907/2006 (REACH)	16
	4.1.2 Product information as per European Pressure Equipment Directive 2014/68/EU (PED).....	16
	4.1.3 Product information as per Directive 2014/34/EU (ATEX)	16
	4.2 Marking	16
	4.3 SISTO-C	18
	4.3.1 General description	18
	4.3.2 Operating data.....	18
	4.3.3 Design details.....	18
	4.3.4 Function.....	21
	4.4 Scope of supply	22
	4.5 Dimensions and weights.....	22
5	Installation at Site.....	23
	5.1 General information/Safety regulations	23
	5.2 Installation position.....	23
	5.2.1 Special design.....	24
	5.3 Preparing the valve.....	24
	5.4 Piping.....	24
	5.4.1 Welding into the pipe	24
	5.5 Insulation	25
6	Commissioning/Start-up/Shutdown	26
	6.1 Commissioning/Start-up	26

6.1.1	Prerequisites for commissioning/start-up	26
6.1.2	Actuation/operation	26
6.1.3	Setting the travel stop	27
6.2	Operating limits	30
6.2.1	Pressure/temperature ratings	30
6.3	Shutdown	30
6.3.1	Measures to be taken for shutdown	30
7	Servicing/Maintenance	31
7.1	Safety regulations	31
7.2	Servicing/inspection	31
7.2.1	Maintenance	31
7.2.2	Supervision of operation	32
7.2.3	Moving the diaphragm valve/diaphragm valve with piston actuator into closed position	33
7.2.4	Moving the diaphragm valve/diaphragm valve with piston actuator into open position	33
7.2.5	Replacing the diaphragm	34
7.2.6	Valve reassembly	35
7.3	Tightening torques of SISTO-C	36
7.4	Tightening torques of SISTO-B	36
8	Trouble-shooting	37
9	Related Documents	38
9.1	General assembly drawings with list of components, SISTO-C	38
9.2	General assembly drawings with list of components, SISTO-B	41
9.3	Dimensions to ISO – precision (investment) cast body	43
9.4	Dimensions to OD ASME BPE – precision (investment) cast body	44
9.5	Dimensions to DIN – forged body	45
9.6	Dimensions to ISO – forged body	46
9.7	Dimensions to OD ASME BPE – forged body	48
9.8	Dimensions to SMS – forged body	49
9.9	Specifications	50
10	Mounting / Installation Accessories and Variants	51
10.1	General description	51
10.2	Mechanical open-position travel stop	51
10.3	Mechanical closed-position travel stop	53
10.4	SK.500/.510 electrical actual-position feedback unit with inductive limit switch	54
10.5	SK.500/.510 electrical actual-position feedback unit with inductive limit switch and travel stop	57
10.6	SK.500/.510 electrical actual-position feedback unit with mechanical limit switch	60
10.7	Directly mounted inductive actual-position feedback unit for open position	62
10.8	LAP.525 two-stage actuator	64
10.9	Samson 3730-X electro-pneumatic positioner	66
10.10	Inductive actual-position feedback unit for open position and/or closed position	68
11	Setting and Using Variants for SISTO-C Diaphragm Valves	69
11.1	Mechanical closed-position and open-position travel stop	69
11.2	Upper section of the diaphragm valve with handwheel locking device and padlock	70
11.3	Upper section of the diaphragm valve with stainless steel handwheel and stem extension	71
11.4	Upper section of the diaphragm valve with handwheel and limit switches	72
11.5	Upper section of the diaphragm valve with handwheel and pneumatic fail-safe action	73
12	EU Declaration of Conformity of SISTO-C/-B	74
	Index	75

Glossary

ATEX 2014/34/EU

The acronym ATEX is the French abbreviation for explosive atmospheres: "Atmosphère explosible". The ATEX product directive 2014/34/EU lays down rules to be met by equipment and protective systems intended for use in potentially explosive atmospheres in the European Union (EU).

AZ actuator

OPEN/CLOSE = double-acting piston actuator (air-to-open / air-to-close)

EW

Drain angle = angle of body to pipe enabling the fluid to drain completely.

HV

SISTO-C diaphragm valve with handwheel

HV.510

SISTO-C diaphragm valve with plastic handwheel

HV.514/.524

SISTO-C diaphragm valve with handwheel, locking device and padlock

HV.516/.526

SISTO-C diaphragm valve with handwheel and stem extension

HV.518/.528

SISTO-C diaphragm valve with handwheel and inductive open/closed-position limit switch

HV.519/.529

SISTO-C diaphragm valve with handwheel and pneumatic fail-safe action

HV.520

SISTO-C diaphragm valve with stainless steel handwheel

HV.523

SISTO-C diaphragm valve with handwheel and travel stop for closed and open positions (MD 168 and MD 202)

LAP

Pneumatic piston actuator, available in versions SF, OF and AZ

LAP.520

Pneumatic piston actuator, type 520, available in versions AZ, OF and SF

LAP.525

SISTO-C diaphragm valve with pneumatic piston actuator, with full and partial opening

LAP.527

Diaphragm valve with actuator with lower control pressure

Machinery Directive 2006/42/EC (MD)

Directive 2006/42/EC stipulates generally applicable essential safety and health requirements.

MD

Diaphragm diameter, numeric designation of the diaphragm size

OF actuator

Opening spring = pneumatic piston actuator, fail-open (spring-to-open / air-to-close)

Pressure Equipment Directive 2014/68/EU (PED)

The 2014/68/EU Directive sets out the requirements to be met by pressure equipment intended to be placed on the market in the European economic area.

QM system

Quality management system to DIN EN ISO 9001

SF actuator

Closing spring = pneumatic piston actuator, fail-close (air-to-open / spring-to-close)

1 General

1.1 Principles

This operating manual is valid for the type series and variants indicated on the front cover. The operating manual describes the proper and safe use of this equipment in all phases of operation.

In the event of damage, immediately contact SISTO Armaturen to maintain the right to claim under warranty.

1.2 Contact data

SISTO Armaturen S.A.
 Complaint Management
 18, rue Martin Maas
 L-6468 Echternach
 Luxembourg
 Tel.: +352 32 50 85-1
 Fax: +352 32 89 56
 Email: info@sisto-aseptic.com
 www.sisto-aseptic.com

1.3 Target group

This operating manual is aimed at the target group of trained and qualified specialist technical personnel.

1.4 Other applicable documentation

Table 1: Overview of other applicable documents

Document	Contents
SISTO-C 8644.1 type series booklet	Description of the valve
Sub-supplier product literature ¹⁾	Operating manuals and other product literature for the accessories
Type series booklet 8676.5	Description of SISTO-SK-i.310/.320
Reference: operating manual 8676.82 ²⁾	Operating manual: SK-i.310 Intelligent Actual-position Feedback Unit
Reference: operating manual 8676.81 ²⁾	Operating manual: SK-i LED/SK-i AS-i LED Intelligent Actual-position Feedback Unit
SISTO catalogue 8652.10	Sterile Processes catalogue

Observe the relevant manufacturer's product literature for the accessories.

1.5 Available software / web site

SISTO angle measurement

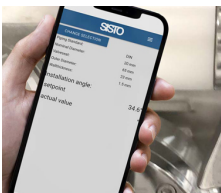

This software can be used to measure the drain angle.
<https://sisto-aseptic.com/files/app3/index.html>



1 If included in agreed scope of supply
 2 This product is described in a separate operating manual.

CAD portal, SISTO

This portal comprises the digital data of the SISTO products. (Click the QR code.)









1.6 Symbols

Table 2: Symbols used in this manual

Symbol	Description
✓	Conditions which need to be fulfilled before proceeding with the step-by-step instructions
▷	Safety instructions
↪	Result of an action
↔	Cross-references
1. 2.	Step-by-step instructions
	Note Recommendations and important information on how to handle the product

1.7 Key to safety symbols/markings

Table 3: Definition of safety symbols/markings

Symbol	Description
 DANGER	DANGER This signal word indicates a high-risk hazard which, if not avoided, will result in death or serious injury.
 WARNING	WARNING This signal word indicates a medium-risk hazard which, if not avoided, could result in death or serious injury.
CAUTION	CAUTION This signal word indicates a hazard which, if not avoided, could result in damage to the machine and its functions.
	Explosion protection This symbol identifies information about avoiding explosions in potentially explosive atmospheres in accordance with EU Directive 2014/34/EU (ATEX).
	General hazard In conjunction with one of the signal words this symbol indicates a hazard which will or could result in death or serious injury.
	Electrical hazard In conjunction with one of the signal words this symbol indicates a hazard involving electrical voltage and identifies information about protection against electrical voltage.
	Machine damage In conjunction with the signal word CAUTION this symbol indicates a hazard for the machine and its functions.



2 Safety

All the information contained in this section refers to hazardous situations.

In addition to the present general safety information the action-related safety information given in the other sections must be observed.

2.1 General

- This operating manual contains general installation, operating and maintenance instructions that must be observed to ensure safe operation of the system and prevent personal injury and damage to property.
- Comply with all the safety instructions given in the individual sections of this operating manual.
- The operating manual must be read and understood by the responsible specialist personnel/operators prior to installation and commissioning.
- The contents of this operating manual must be available to the specialist personnel at the site at all times.
- When assembling components from various manufacturers, the operating manuals of the individual components must also be complied with.
- Information and markings attached directly to the product must always be complied with and kept in a perfectly legible condition at all times. This applies to, for example:
 - Manufacturer
 - Nominal pressure
 - Nominal size
 - Year of construction
 - Valve body material
- The operator is responsible for any eventualities or incidents which may occur during installation performed by the customer, operation and maintenance.
- The operator is responsible for ensuring compliance with all local regulations not taken into account.
- Design, manufacture and testing of the valve are subject to a QM system to DIN EN ISO 9001 as well as to the current European Pressure Equipment Directive 2014/68/EU (PED) and, if applicable, the current Machinery Directive 2006/42/EC (MD).
Compliance with these requirements is based on normal, static loading, e.g.
 - Flow velocities typical of the fluid handled
 - Typical temperature gradients
- The valve is not designed for use in systems handling unstable fluids. Should loads and operating conditions deviate from normal operation, this must be specified by the ordering party. This includes temperature, pressure, special corrosive, chemical or abrasive influences, etc. Suitable measures will be prepared and suggested. Such measures may influence the following:
 - Material selection
 - Wall thickness allowance
 - Variants
- For any queries and repeat orders indicate the following if possible (see name plate):
 - Name of type series / design variant
 - Order number
 - Year of construction
 - Part number

2.2 Intended use

- Only operate valves which are in perfect technical condition.
- Do not operate the valve in partially assembled condition.
- Only use the valve for fluids specified in the product literature. Take the design and material variant into account.
- Only operate the valve within the operating limits described in the other applicable documents.
- The valve's design and rating are based on predominantly static loading in accordance with the codes applied. Consult the manufacturer if the valve is subjected to dynamic loads or any other additional influences.
- Consult the manufacturer about any other modes of operation not described in the product literature.
- Do not use the valve as a foothold.
- The accessories and the variants described are intended for use with type series SISTO-C of diaphragm valves HV.520 and diaphragm valves with piston actuator LAP.520.
- SISTO Armaturen does not accept any liability for damage resulting from improper handling or external influences.

Pneumatic actuators from SISTO are suitable for the control fluid compressed air in accordance with ISO 8573-1.

Table 4: Quality class of control fluid air

	Operation above 0 °C	Operation down to -10 °C
Quality class	5.4.4	5.3.4
Filter	40 µm	40 µm
Oil concentration	5 mg/m ³	5 mg/m ³
Dew point	+3 °C	-20 °C

For determining the required air quality consider the specifications of all components used in the system.

2.2.1 Prevention of foreseeable misuse

- Never exceed the permissible application and operating limits specified in the data sheet or product literature regarding temperature, etc.
- Observe all safety information and instructions in this manual.

2.3 Personnel qualification and training

- All personnel involved must be fully qualified to transport, install, operate, maintain and inspect the product this manual refers to and be fully aware of the interaction between the valve and the system.
- The responsibilities, competence and supervision of all personnel involved in transport, installation, operation, maintenance and inspection must be clearly defined by the operator.
- Deficits in knowledge must be rectified by means of training and instruction provided by sufficiently trained specialist personnel. If required, the operator can commission the manufacturer/supplier to train the personnel.
- Training on the valve must always be supervised by specialist technical personnel.

2.4 Consequences and risks caused by non-compliance with this manual

- Non-compliance with these operating instructions will lead to forfeiture of warranty cover and of any and all rights to claims for damages.
- Non-compliance can, for example, have the following consequences:

- Hazards to persons due to electrical, thermal, mechanical and chemical effects and explosions
- Failure of important product functions
- Failure of prescribed maintenance and servicing practices
- Hazard to the environment due to leakage of hazardous substances

2.5 Safety awareness

In addition to the safety information contained in this operating manual and the intended use, the following safety regulations shall be complied with:

- Accident prevention, health regulations and safety regulations
- Explosion protection regulations
- Safety regulations for handling hazardous substances
- Applicable standards, directives and laws

2.6 Safety information for the operator/user

The valves are intended for use in areas which cannot be accessed by unauthorised persons. Operation of these valves in areas accessible to unauthorised persons is only permitted if appropriate protective devices are fitted at the site. This must be ensured by the operator.

- Fit protective equipment (e.g. contact guards) supplied by the operator for hot, cold or moving parts, and check that the equipment functions properly.
- Do not remove any protective equipment (e.g. contact guards) during operation.
- Provide the personnel with protective equipment and make sure it is used.
- Contain any leakage of hazardous fluids (e.g. explosive, toxic, hot) so as to avoid any danger to persons and the environment. Adhere to all relevant laws.
- Eliminate all electrical hazards. (In this respect refer to the applicable national safety regulations and/or regulations issued by the local energy supply companies.)
- To be considered for system planning: SISTO diaphragm valves are designed in such a way that any rupture of the diaphragm will be indicated by fluid handled escaping from a leakage indication hole in the bonnet or from the stem protection below the handwheel.
- For design variants with re-pluggable leakage indication hole/opening in fully sealed diaphragm valves contact the manufacturer.
- Guards for live components must be regularly checked for any damage. The valve must never be operated without appropriate protection.

2.7 Safety information for maintenance, inspection and installation

- Modifications or alterations of the valve require the manufacturer's prior consent.
- Use only original spare parts or parts/components authorised by the manufacturer. The use of other parts/components can invalidate any liability of the manufacturer for resulting damage.
- The operator ensures that maintenance, inspection and installation are performed by authorised, qualified specialist personnel who are thoroughly familiar with the manual.
- Carry out work on the valve during standstill only.
- The valve body must have cooled down to ambient temperature.
- The pressure in the valve body must have been released and the valve must have been drained.
- When taking the valve out of service always adhere to the procedure described in the manual.

- Decontaminate valves which handle fluids posing a health hazard.
- Protect the valve body and body bonnet/cover from any impacts.
- As soon as the work has been completed, re-install and re-activate any safety-relevant devices and protective devices. Before returning the product to service, observe all instructions on commissioning. (⇒ Section 6.1, Page 26)

2.8 Unauthorised modes of operation

- The valve is operated outside the limits stated in the operating manual.
- The valve is not operated in accordance with the intended use.

2.9 Information on explosion protection



Always observe the information on explosion protection given in this section when operating the product in potentially explosive atmospheres.



Safety

This symbol indicates safety measures which must be specially observed to avoid personal injury and damage to property when using valves in potentially explosive atmospheres in accordance with EU Directive ATEX 2014/34/EU.

- Prevent impermissible modes of operation at all times. Exceeding the specified temperature limits is not permitted.
- In potentially explosive atmospheres, the operator shall install and operate exclusively explosion-proof equipment.

Installation

- Valves used in potentially explosive atmospheres must be included in the system's potential equalisation.
- For use in potentially explosive atmospheres, the spring area of pneumatic piston actuators has to be connected to an explosion-proof air reservoir.

Operation

- The surface temperature at the valve body corresponds to the temperature of the fluid handled. Responsibility for compliance with the specified fluid temperature (operating temperature) always lies with the plant operator. The maximum permissible fluid temperature depends on the temperature class to be complied with.
- Heating up of the valve components by sun exposure or ambient temperature must be prevented.
- Prevent other than normal loads (such as external forces and moments).

Servicing/Maintenance

- The operator is responsible for servicing and maintenance work. This work must be performed such that no source of ignition (e.g. electrostatic discharge, mechanically generated sparks) is caused or triggered.
- Perfect sealing to atmosphere, at the body as well as at the various seals, must be checked by the operator at regular intervals, using a special maintenance schedule for example.
- Prevent dust and dirt deposits on the valve surface.
- Always use a damp cotton cloth for cleaning plastic surfaces or plastic-coated surfaces in order to prevent electrostatic charging.
- Use original SISTO spare parts only.
- For actuators made of aluminium, contact with iron oxides must be ruled out to prevent thermite reactions. In addition, protect the valve against mechanical impacts.

Marking

- Since valves are components which do not have their own potential source of ignition, they are not covered by Directive 2014/34/EU and must therefore not be marked "ATEX".

If the instructions laid down for safety, installation, operation and maintenance/ servicing are not complied with, proper operation of the valve within the meaning of Directive 2014/34/EU is not ensured. In this case, the valves must not be installed in potentially explosive atmospheres. Defective valves must never be operated in potentially explosive atmospheres.

3 Transport/Storage/Disposal

3.1 Checking the condition upon delivery



Unless otherwise agreed, valves are supplied ready for operation.

1. On transfer of goods, check each packaging unit for damage.
2. In the event of in-transit damage, assess the exact damage, document it and notify the supplying dealer and the insurer about the damage in writing immediately.

3.2 Packaging

Dispose of packaging material in accordance with local regulations.

3.3 Transport

	<p style="background-color: #f4a460; padding: 5px;">⚠ WARNING</p> <p>Improper lifting of heavy components Risk of injury from lifting heavy components!</p> <ul style="list-style-type: none"> ▸ Ensure that suitable ergonomic handling equipment is used. ▸ Select suitable lifting equipment and lifting accessories for the component weight. ▸ Observe the applicable accident prevention regulations.
	<p style="background-color: #f4d03f; padding: 5px;">CAUTION</p> <p>Improper transport Overload</p> <ul style="list-style-type: none"> ▸ Use the lifting lugs provided. ▸ The lifting lugs of valves with pneumatic actuator are designed for a maximum load of 85 kg. Should this weight be exceeded, suspend the valve differently for transport (e.g. at the body). ▸ The valves must never be suspended by the handwheel or by the mounted actuator. ▸ Transport the valves taking into account the centre of gravity.

Take suitable precautions to prevent damage during transport.

Ensure sufficient stability. Use suitable standard-compliant transport equipment.

The connection ports are closed with suitable material (caps, plugs, covers).

3.4 Storage/preservation

	<p style="background-color: #f4d03f; padding: 5px;">CAUTION</p> <p>Incorrect storage Damage due to dirt, corrosion, humidity and/or frost!</p> <ul style="list-style-type: none"> ▸ Close the valve using little force and store in the closed position. ▸ Store the valve in a frost-proof room with a constant level of atmospheric humidity. ▸ Store the valve in a dust-free environment, e.g. use suitable caps or film for protection. ▸ Protect the valve from contact with solvents, lubricants, fuels or other chemicals. ▸ Store the valve in a vibration-free environment. ▸ Avoid UV radiation and direct sunlight.
---	---

Measures to be taken for prolonged periods of storage

The following measures are recommended to be taken before prolonged periods of storage:



1. Storage and/or temporary storage of the valves must ensure that, even after a prolonged period of storage, the valves' function is not impaired.
2. Store the valve in the closed position to protect the seating surfaces against damage. Store the pneumatic actuator with the connections closed to protect the sealing surfaces against damage.
3. The storage room temperature must be between +10 °C and +30 °C.
4. For storing a valve that has already been operated, observe the measures to be taken for shutdown. (⇒ Section 6.3, Page 30)



3.5 Return to supplier

1. Drain the valve as described in the manual.
2. Flush and clean the valve, particularly if it has been used for handling noxious, explosive, hot or other hazardous fluids.
3. If the valve has handled fluids whose residues could lead to corrosion damage in the presence of atmospheric humidity or could ignite upon contact with oxygen, also neutralise the valve and blow through with anhydrous inert gas to ensure drying.
4. Always complete and enclose a certificate of decontamination when returning valves used for fluid group 1.
Indicate any safety measures and decontamination measures taken.

	NOTE
	If required, a blank certificate of decontamination can be downloaded from the following web site: www.ksb.com/certificate_of_decontamination

3.6 Disposal

	 WARNING
	<p>Fluids handled, consumables and supplies which are hot or pose a health hazard Hazard to persons and the environment!</p> <ul style="list-style-type: none"> ▷ Collect and properly dispose of flushing fluid and any residues of the fluid handled. ▷ Wear safety clothing and a protective mask if required. ▷ Observe all legal regulations on the disposal of fluids posing a health hazard.

	 DANGER
	<p>Pre-loaded springs! Risk of injury!</p> <ul style="list-style-type: none"> ▷ Actuators of the spring-to-open or spring-to-close type are fitted with a spring mechanism. ▷ The spring energy of pre-loaded springs must be released before disposal. <p>⇒ Danger to life by releasing spring energy!</p>

1. Dismantle the valve.
Collect greases and other lubricants during dismantling.
2. Separate and sort the valve materials, e.g. by:
 - Metals
 - Plastics
 - Electronic waste
 - Greases and other lubricants

3. Dispose of materials in accordance with local regulations or in another controlled manner.

4 Description

4.1 Product information

4.1.1 Product information as per Regulation No 1907/2006 (REACH)

For information as per chemicals Regulation (EC) No. 1907/2006 (REACH), see <https://sisto-aseptic.com/infopage/>.

4.1.2 Product information as per European Pressure Equipment Directive 2014/68/EU (PED)

The valves satisfy the safety requirements of Annex I of the European Pressure Equipment Directive 2014/68/EU (PED) for fluids in Groups 1 and 2.

4.1.3 Product information as per Directive 2014/34/EU (ATEX)

Valves without electrical components do not have a potential internal source of ignition and can be used in potentially explosive atmospheres, Group II, category 1 (zones 0+20), category 2 (zones 1+21) and category 3 (zones 2+22) to ATEX 2014/34/EU. Components such as electric actuators, position switches, block terminals, solenoid valves, etc. may in certain circumstances be covered by Article 1 of Directive 2014/34/EU. They must be subjected to a conformity assessment procedure and separate evidence of compliance must be provided (e.g. EC Declaration of Conformity or manufacturer's declaration).

4.2 Marking

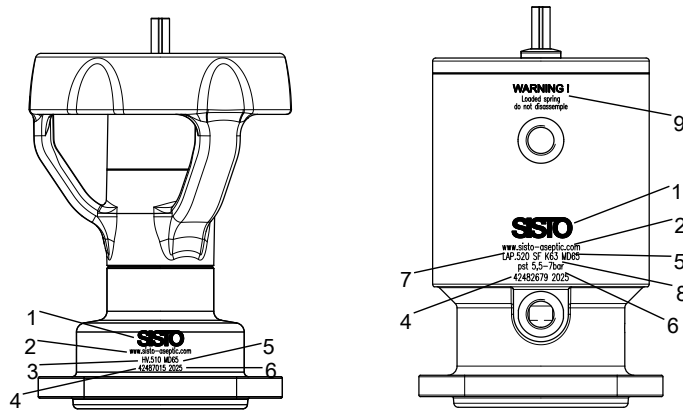

Fig. 1: SISTO-C upper valve section marking (example)

1	Manufacturer's mark	6	Year of construction
2	Web site	7	Type and function
3	Type	8	Control pressure
4	Part No. of the upper valve section	9	Warnings (for SF and OF versions only)
5	Diaphragm seat		

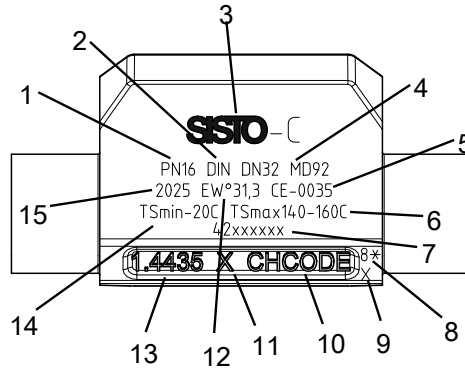

Fig. 2: SISTO-C body marking (example)

1	Nominal pressure	9	Worker's stamp/measurement report
2	Piping standard	10	Batch
3	Manufacturer's mark	11	Manufacturer's mark
4	Diaphragm seat	12	Drain angle
5	CE conformity marking	13	Material
6	Permissible maximum temperature ³⁾	14	Permissible minimum temperature
7	Part number of body	15	Year of construction
8	Surface finish code		

In accordance with the current European Pressure Equipment Directive (PED), valves \geq DN 32 have a CE conformity marking.

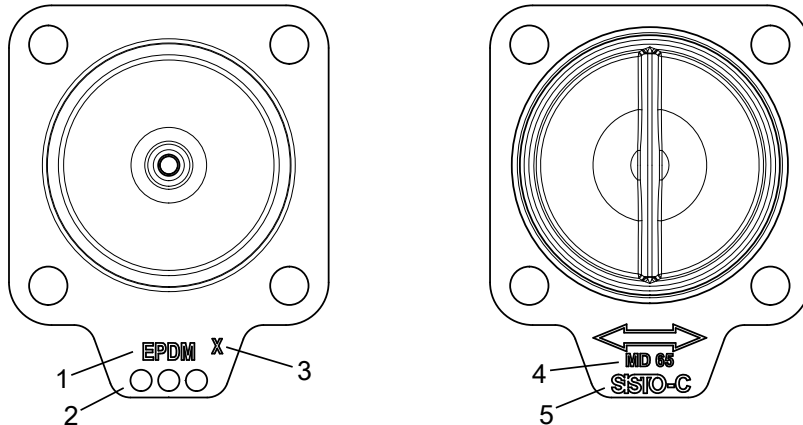

Fig. 3: SISTO-C diaphragm marking (example)

1	Material	4	Diaphragm seat
2	Date of manufacture (day-month-year)	5	Type series
3	Cavity number		

³ The maximum permissible temperature for the valve is defined by the diaphragm material. (Table "Diaphragm materials" (\Rightarrow Section 4.3.3, Page 19))

4.3 SISTO-C

4.3.1 General description

- Diaphragm valve with butt weld ends or clamp ferrules
- Valve for shutting off fluids in the pharmaceutical and food industry

4.3.2 Operating data

SISTO-C manually operated valve



Fig. 4: SISTO-C

Table 5: Operating properties

Characteristic	Value
Nominal pressure	PN 16
Nominal size ⁴⁾	DN 6 - 200
Max. permissible pressure [bar] ⁵⁾	16
Min. permissible temperature [°C] ⁶⁾	≥ -20
Max. permissible temperature [°C] ⁶⁾	≤ +160

SISTO-C LAP actuated valve

Table 6: Operating properties

Characteristic	Value
Nominal pressure	PN 16
Nominal size ⁴⁾	DN 6 - 200
Max. permissible pressure [bar] ⁵⁾	16
Min. permissible temperature [°C] ⁶⁾	≥ -20
Max. permissible temperature [°C] ⁶⁾	≤ +160
Control fluid	Compressed air (min. 5.5 bar) ⁷⁾ (max. 7.0 bar)

4.3.3 Design details

Design

- Soft-seated weir-type shut-off valve in straight-way pattern, Y-pattern, T-pattern and multi-port pattern, either manually operated or with pneumatic piston actuator
- Shut-off and sealing to atmosphere by completely enclosed diaphragm; no dead volumes; suitable for sterilisation
- Suitable for CIP/SIP
- Self-drain angle marked on weld ends⁸⁾ and in marking area
- Manufactured and tested to EN 13397
- Marked in accordance with DIN EN 19 (ISO 5209)
- Marked in accordance with ASME BPE

4 Smaller and larger nominal sizes available on request

5 Versions for higher operating pressures are available on request.

6 The temperatures indicated are for orientation only; they are not valid for all operating conditions.

7 Control pressure below 5.5 bar available on request.

8 Forged body only

Variants

- Tank valves or multi-port valves⁹⁾
- Limit switches
- SISTO-SK-i actual-position feedback unit
- SISTO-SK-i actual-position feedback unit with integrated solenoid valve
- Positioners
- Adjustable travel stop
- HV.514/.524: diaphragm valve with handwheel, locking device and padlock
- HV.516/.526: diaphragm valve with handwheel and stem extension
- HV.518/.528: diaphragm valve with handwheel and inductive Open/Closed limit switch
- HV.519/.529/SISTO-CSPV: diaphragm valve with handwheel and pneumatic fail-safe action
- HV.520: diaphragm valve with stainless steel handwheel
- HV.523: Diaphragm valve with handwheel and travel stop for closed and open positions (MD168 and MD202)
- LAP.523: diaphragm valve with pneumatic piston actuator, high-temperature version for temperatures ≥ 80 °C to 120 °C (max.) at the actuator cylinder
- LAP.525: diaphragm valve with pneumatic piston actuator, with full and partial opening (2-stage actuator)
- LAP.526: diaphragm valve with pneumatic piston actuator with overflow function
- LAP.527: diaphragm valve with actuator with lower control pressure

Diaphragm materials**Table 7:** Overview of diaphragm qualities

Diaphragm	Temperature limit [°C]
SISTO-AseptiXX EPDM	+140
SISTO-AseptiXX TFM/EPDM, bonded	
SISTO-AseptiXX TFM/EPDM, 2-piece	+160

⁹ For further designs refer to the "Sterile Processes" catalogue, reference No. 8652.10.

Surface finish

Table 8: Surface finish of wetted internal body surfaces¹⁰⁾

Ground				Electropolished ¹¹⁾			
Ra [μm] ¹²⁾	Ra [μin]	ASME BPE code	Hygiene class DIN 11866	Ra [μm] ¹²⁾	Ra [μin]	ASME BPE code	Hygiene class DIN 11866
6,3	250	SF0	-	-	-	-	-
3,2	125	-	-	-	-	-	-
1,6	60	-	-	-	-	-	-
0,8	30	SF3	H3	0,8	30	-	HE3
0,6	25	SF2	-	0,6	25	SF6	-
0,5	20	SF1	-	0,5	20	SF5	-
0,4	15	-	H4	0,4	15	SF4	HE4
-	-	-	-	0,25	10	-	HE5

Manually operated valve

Table 9: Overview of materials of manually operated valve

MD	Type	Bonnet	Handwheel
30 - 115	HV.510	Stainless steel 1.4409	PA66GF30
30 - 202	HV.520	Stainless steel 1.4409	Stainless steel 1.4409
280 ¹³⁾	HV	-	-

Drive

Table 10: Overview of materials of pneumatic piston actuator

MD	Type	Bonnet	Piston actuator
30 - 202	LAP.520	Stainless steel 1.4409	Stainless steel 1.4409 / 1.4301
280	LAP	-	-

10 Surface finish to ASME BPE SF 2.2

11 Precision (investment) castings available in Ra 0.8, Ra 0.6 and Ra 0.5, electropolished

12 Exact values in accordance with ASME BPE: 0.76 μm / 0.64 μm / 0.51 μm / 0.38 μm

13 Design as per customer specifications

4.3.4 Function

Design of diaphragm valve with handwheel

The diaphragm valve comprises the body 100, the functional unit (bonnet 165, stem 200, compressor 553 and diaphragm 443) as well as the actuating element (handwheel 961). The diaphragm valve is closed by turning the handwheel (961) clockwise. The diaphragm valve is opened by turning the handwheel (961) counter-clockwise. (⇒ Fig. 5) shows a closed valve. The position indicator 621 is retracted. When the valve is open, it protrudes from the upper valve section.

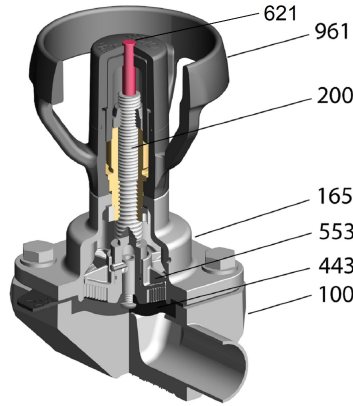

Fig. 5: SISTO-C HV.510

Design of diaphragm valve with pneumatic piston actuator

Diaphragm valves with pneumatic piston actuator are available in the following versions:

- "Fail-close" = SF
 - Air-to-open/spring-to-close
- "Fail-open" = OF
 - Spring-to-open/air-to-close
- "Double-acting" = AZ (OPEN/CLOSE)
 - Air-to-open/air-to-close

	NOTE
<p>The fail-safe position is automatically adopted if the control air supply fails, regardless of whether this is intentional or unintentional. The visible moving parts of the valve serve as valve position indicators, regardless of whether the valve is actuated manually or automatically.</p>	

Design of diaphragm valve SISTO-C LAP

The diaphragm valve comprises the body 100 and the functional unit (pneumatic piston actuator SF/OF/AZ). The piston actuator comprises a bonnet 165 with an M5 / G 1/8" control air port (DIN ISO 228-1), cover 160.3, compressor 553, piston rod 209, position indicator 621.3, piston 595.1, spring 950.2 and diaphragm 443.

Version of diaphragm valve SISTO-C LAP.520

The diaphragm valve comprises the body 100 and the functional unit (pneumatic piston actuator SF/OF/AZ). The piston actuator comprises a bonnet 165 with an M5 control air port for MD 30 - MD 40, G 1/8 inch for MD 65-MD 202) (ISO 228-1), cover 160.3, compressor 553, piston rod 209, position indicator 621.3, piston 595.1, spring 950.2 and diaphragm 443.

LAP.520-SF fail-close:

- When not actuated, the diaphragm valve is in the closed position.
- This position is reached by spring force.
- The diaphragm valve is opened by applying compressed air to the lower air port.

LAP.520-OF fail-open:

- When not actuated, the diaphragm valve is in the open position.
- This position is reached by spring force.
- The diaphragm valve is closed by applying compressed air to the upper air port.

LAP.520-AZ: double-acting:

- The diaphragm valve is closed by applying compressed air to the upper control air port.
- The diaphragm valve is opened by applying compressed air to the lower control air port.
- In the event of compressed air supply failure, the valve does not adopt a defined position.

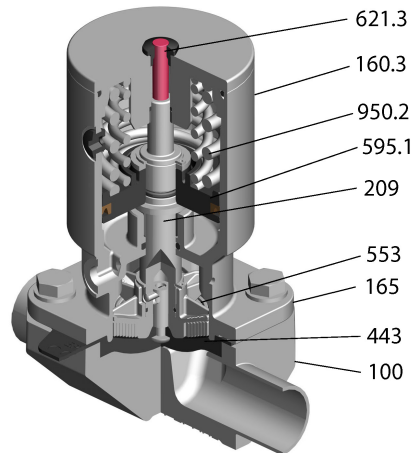
**Fig. 6:** SISTO-C LAP.520

- Design of diaphragm valve** The diaphragm valve comprises the body 100 and the functional unit (pneumatic piston actuator SF/OF/AZ). The piston actuator comprises the bonnet 165 with a G 1/8" control air port (DIN ISO 228-1), compressor 553, piston rod 209, bottom end cap 176.1, cover 160.3, piston 595.1, spring 950.1, spring plate 484.1 and diaphragm 443.
- SISTO-B**
- Function** The diaphragm valves can be operated either manually by a handwheel or pneumatically by a piston actuator.
- Sealing** Body 100 and bonnet 165 are connected by hexagon head bolts 901. The fluid flowing through the valve is shut off and sealed to atmosphere by diaphragm 443.

4.4 Scope of supply

Depending on the design variant, the following components are included in the scope of supply:

- Valve
- Operating manual for accessories (if applicable)
- Pneumatic actuator

4.5 Dimensions and weights





Dimensions and weights to DIN (⇒ Section 9.5, Page 45) , to ISO (⇒ Section 9.6, Page 46) , to OD (⇒ Section 9.7, Page 48) , to SMS (⇒ Section 9.8, Page 49) .

5 Installation at Site

5.1 General information/Safety regulations

The operator ensures that maintenance, inspection and installation are performed by authorised, qualified specialist personnel who are thoroughly familiar with the manual.

Responsibility for positioning and installing the valve lies with the consultant, the engineering contractor or the operator. Planning errors and installation errors prevent the reliable function of the valves and may pose a substantial safety hazard.

	<p>⚠ DANGER</p> <p>Dead-end valve High-pressure hazard! Risk of burns!</p> <ul style="list-style-type: none"> ▷ Protect the valve against unauthorised and/or unintentional opening. This particularly applies to abnormal operating conditions. ⇒ Escaping fluid may cause injuries. ⇒ Wear safety clothing and a protective mask if required.
	<p>⚠ WARNING</p> <p>Exposed moving parts Risk of injury!</p> <ul style="list-style-type: none"> ▷ Do not touch moving components. ▷ When the equipment is in operation, perform any work with utmost caution. ▷ Take suitable precautions, e.g. provide safety covers.
	<p>CAUTION</p> <p>Weld spatter, scale and other impurities in the piping Damage to the valve!</p> <ul style="list-style-type: none"> ▷ Remove any impurities from the piping.
<ol style="list-style-type: none"> 1. Thoroughly clean, flush and blow through all vessels, pipes and connections (especially of new installations). 2. Remove the valve's flange covers before installing it in the pipe. 3. Check that the inside of the valve is free from any foreign objects. Remove any foreign objects. 	
	<p>NOTE</p> <p>The material, pressure data and temperature data of the valve must be compatible with the operating conditions of the piping. The material's chemical resistance and stability under load have been checked.</p>

5.2 Installation position

Diaphragm valves can be installed in any position. For 2/2 directional control valves, installation at the corresponding self-drain angle (max. tolerance -3°) is recommended (see dimensions to DIN (⇒ Section 9.5, Page 45), dimensions to ISO (⇒ Section 9.6, Page 46), dimensions to OD (⇒ Section 9.7, Page 48), dimensions to SMS (⇒ Section 9.8, Page 49)).

5.2.1 Special design

	NOTE
	<p>For positioning and installing special valve designs contact the consultant, construction company or operator.</p>

5.3 Preparing the valve

	⚠ DANGER
	<p>Valve under pressure Risk of injury! Leakage of hot and/or toxic fluids! Risk of burns!</p> <ul style="list-style-type: none"> ▶ Depressurise the valve and its surrounding system prior to any maintenance work and installation work. ▶ If there is fluid leakage, depressurise the valve. ▶ Allow the valve to cool down until the temperature of the fluid in all valve areas in contact with the fluid is lower than the fluid's vaporisation temperature. ▶ Never vent the valve by undoing the bonnet bolting or the flange bolting between valve and pipe, or by opening the screw plugs. ▶ Use original spare parts and appropriate tools, even in emergencies.

	NOTE
	<p>Remove the caps on the connection ports immediately prior to installation.</p>





5.4 Piping

	CAUTION
	<p>Impermissible piping forces Leakage from or rupture of the valve body!</p> <ul style="list-style-type: none"> ▶ Connect the pipes to the valve without transmitting any stresses or strains. ▶ Take structural measures to prevent any piping forces from being transmitted to the valve. ▶ Avoid mechanical loads beyond normal levels (e.g. piping forces, moments and vibrations).

	CAUTION
	<p>Painting of the piping Valve function impaired! Loss of important information provided on the valve!</p> <ul style="list-style-type: none"> ▶ Protect stem and plastic components prior to applying paint. ▶ Protect printed name plates prior to applying paint.

5.4.1 Welding into the pipe

Responsibility for welding the valve into the pipe and for any heat treatment required lies with the commissioned construction company or the plant operator.

	<p>CAUTION</p>
	<p>Weld spatter, scale and other impurities Damage to the valve!</p> <ul style="list-style-type: none"> ▸ Take suitable measures to protect the valve against impurities. ▸ Protect the seat of the diaphragm. ▸ Remove any impurities from the piping. ▸ If necessary, install a strainer.
	<p>CAUTION</p>
	<p>Incorrect welding into the pipe Damage to the valve by scorching!</p> <ul style="list-style-type: none"> ▸ To prevent scorching, welding cables must not be attached to valves whose functional valve elements or valve surface have to meet specific roughness requirements.
	<p>CAUTION</p>
	<p>Non-compliance with the max. permissible application temperature Damage to the valve!</p> <ul style="list-style-type: none"> ▸ Complete the weld seam in several steps to ensure that the temperature in the middle of the body does not exceed the max. permissible application temperature.
	<p>NOTE</p>
	<p>Prior to welding the valve body into the pipe, remove the upper valve section including diaphragm. (⇒ Section 7, Page 31)</p>

5.5 Insulation

If the valve is used for handling hot fluids, insulate it in accordance with the German energy-saving regulations.

	<p>⚠ WARNING</p>
	<p>Cold/hot piping and/or valve Risk of thermal injury!</p> <ul style="list-style-type: none"> ▸ Insulate the valve. ▸ Fit warning signs.

For any insulation fitted on the valve observe the following:

- The valve's function must not be impaired.



6 Commissioning/Start-up/Shutdown

6.1 Commissioning/Start-up

6.1.1 Prerequisites for commissioning/start-up

Before commissioning/start-up of the valve, ensure that the following requirements are met:

- The material, pressure data and temperature data of the valve are compatible with the operating conditions of the piping.
- The material's chemical resistance and stability under load have been checked.

	<p>⚠ DANGER</p>
	<p>Risk of pressure surges Danger to life caused by burns, scalds or chemical burns!</p> <ul style="list-style-type: none"> ▷ Do not exceed the valve's maximum permissible pressure. ▷ The operator shall provide general safety measures for the system.
	<p>CAUTION</p>
	<p>Aggressive flushing liquids Damage to the valve!</p> <ul style="list-style-type: none"> ▷ Ensure that cleaning procedure and duration match the valve body materials and seal materials when performing flushing and pickling. ▷ The responsibility for the media and method used for cleaning the piping system lies with the operator.

Functional and leak testing Check the following functions:



1. Check the shut-off function and tightness of the installed valve by opening and closing the valve several times.
2. Prior to re-tightening the screwed/bolted connections of manually operated valves, open the valve by approx. two full counter-clockwise handwheel turns to avoid stress or distortion.
3. Evenly re-tighten the screwed/bolted connections between body 100 and bonnet 165. Check the tightening torques. (⇒ Section 7.3, Page 36) / (⇒ Section 7.4, Page 36)

	<p>NOTE</p>
	<p>To maintain functional reliability, new sealing elements must be used when the valve is reassembled. After reassembly and prior to commissioning/start-up, the overhauled valves must be subjected to shell and leak testing to DIN EN 12266-1.</p>

6.1.2 Actuation/operation

	<p>NOTE</p>
	<p>Viewed from above, the valve is closed by turning the handwheel in clockwise direction, and opened by turning the handwheel in counter-clockwise direction. Valve variants which deviate from this rule are marked accordingly.</p>

	<p>NOTE</p>
	<p>Diaphragm valves are normally used in either "fully open" or "fully closed" position.</p>

	NOTE
	Depending on the actuator design, the pneumatic actuator is operated by applying or removing compressed air. For details refer to (⇒ Section 4.3.4, Page 21) .
	CAUTION
	<p>Impermissible load Excessive wear!</p> <ul style="list-style-type: none"> ▶ If resistance can be felt while opening or closing the valve, the valve has reached its end position and actuation must be stopped. ▶ Continued actuation may result in increased wear of the valve.
	CAUTION
	<p>Use of additional levers Damage to the valve as a result of excessive forces!</p> <ul style="list-style-type: none"> ▶ Never use additional levers to operate the valve. ▶ Only actuate handwheel-operated valves by hand.

6.1.3 Setting the travel stop

**SISTO-C HV.11/.21 MD 30.4
SISTO-B ML 32**

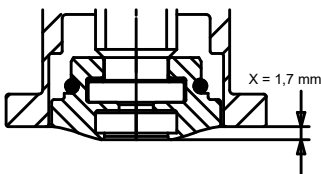

Fig. 7: SISTO-B ML 32:
Overhang X in closed position

Diaphragm valves of the SISTO-C HV.11/.21 MD 30.4 and SISTO-B ML 32 type series are fitted with an integrated, adjustable closed-position travel stop.

Factory setting of closed-position travel stop:

Compressor 553 is set to overhang X in relation to bonnet 165. (⇒ Fig. 7) / (⇒ Fig. 9) This setting ensures tight shut-off in closed position and protects diaphragm 443 against overloading.

Setting the travel stop:

1. Pull handwheel 961 together with cover 160.5 upward and off stem 200.
2. Unscrew threaded disc 514.1.
3. Fit handwheel 961 again. Set the end position of the valve in closing direction as required.
4. Remove handwheel 961. Screw threaded disc 514.1 onto stem 200 by turning it clockwise until it abuts bonnet 165.
5. Fit handwheel 961 again on threaded disc 514.1 and stem 200.
6. Insert cover 160.5 into handwheel 961. This secures stem 200 (⇒ Fig. 8) .

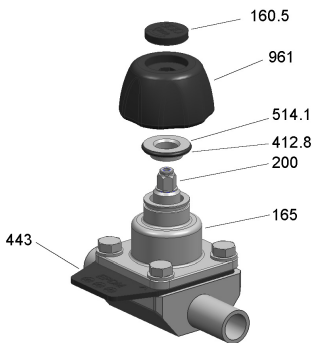

Fig. 8: SISTO-C HV.11/.21 MD 30.4: Setting the closed-position travel stop

SISTO-C HV.510/.520 MD 30

Diaphragm valves of the SISTO-C HV.510/.520 MD 30 type series are fitted with an integrated, adjustable closed-position travel stop.

Factory setting of closed-position travel stop:

Compressor 553 is set to overhang X in relation to bonnet 165. (⇒ Fig. 9) , (⇒ Table 11) This setting ensures tight shut-off in closed position and protects diaphragm 443 against overloading.

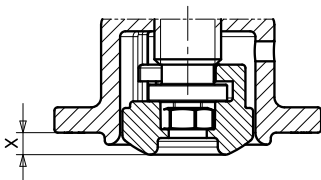

Fig. 9: SISTO-C MD 30:
Overhang X in closed position (⇒ Table 11)

Table 11: Closed-position setting dimension of manually operated valves SISTO-C HV.510/.520 / SISTO-C HV.11/.21

Diaphragm diameter (MD)	Overhang X in closed position (mm)
30	4,1
40	4,8

Diaphragm diameter (MD)	Overhang X in closed position (mm)
65	10,2
92	15,7
115	19,2
168	27,2
202	33,0

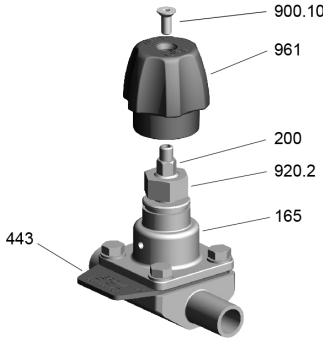

Fig. 10: SISTO-C HV.510/.520 MD 30: Setting the closed-position travel stop

Setting the travel stop:

1. Remove screw 900.10. Remove handwheel 961. Unscrew and remove nut 920.2.
2. Fit handwheel 961 again. Set the end position of the valve in closing direction as required.
3. Remove handwheel 961. Screw nut 920.2 onto stem 200 by turning it clockwise until it abuts bonnet 165.
4. Fit handwheel 961 again on nut 920.2 and stem 200.
5. Fit and tighten screw 900.10 in handwheel 961. This secures stem 200. (⇒ Fig. 10)

SISTO-C HV.510/.520 MD 40 - MD 115

Diaphragm valves of the SISTO-C HV.510/520 MD 40-MD 115 type series are fitted with an integrated, adjustable closed-position and open-position travel stop.

Factory setting of closed-position travel stop:

Compressor 553 is set to overhang X in relation to bonnet 165 (⇒ Fig. 11) . This setting ensures tight shut-off in closed position and protects diaphragm 443 against overloading.

Factory setting of open-position travel stop:

Full valve travel is possible. In this position, the cylindrical section of locating sleeve 527.2 is flush with the upper edge of the inner section of handwheel 961 (⇒ Fig. 13) .

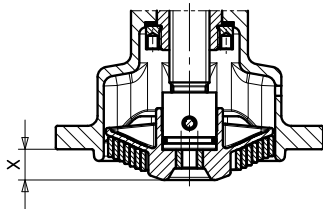

Fig. 11: SISTO-C HV.510/.520 MD 40 - MD 115: Overhang X in closed position

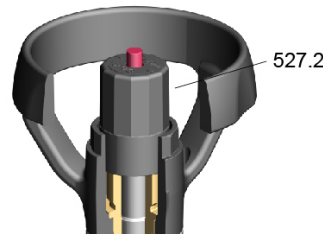

Fig. 12: Setting the open-position travel stop

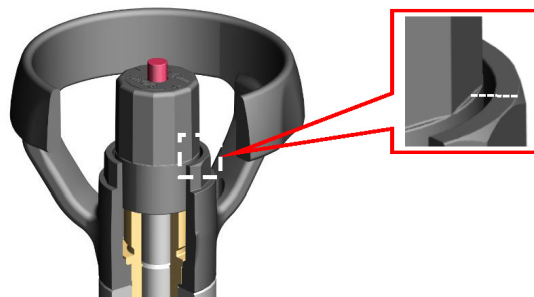
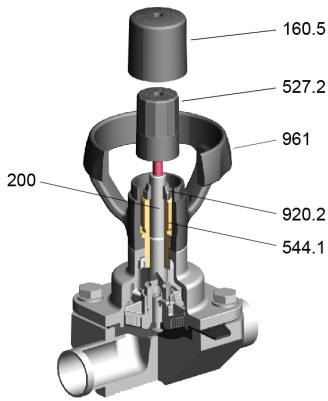

Fig. 13: Locating sleeve flush with upper edge of handwheel



Setting the closed-position travel stop:

1. Remove cover 160.5. Screw locating sleeve 527.2 upwards and remove it.
2. Screw nut 920.2 upwards until the required end position of the valve in closing direction can be set.
3. Screw nut 920.2 downwards on stem 200 by turning it clockwise until it abuts threaded bush 544.1.
4. Screw on locating sleeve 527.2 until its cylindrical section is flush with the upper edge of the handwheel.
5. Fit cover 160.5 again on handwheel 961 and locating sleeve 527.2 (⇒ Fig. 14) .

Fig. 14: SISTO-C
HV.510/.520
MD 40 - MD 115:
Setting the closed-position
travel stop

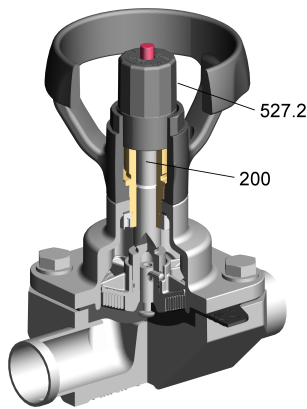

Setting the open-position travel stop:

1. Move the valve to the required position. Turn locating sleeve 527.2 clockwise until it abuts stem 200. (⇒ Fig. 15)
2. Observe the note on locating sleeve 527.2 regarding the travel adjustment per turn.
3. Fit cover 160.5 on handwheel 961 and locating sleeve 527.2 again.

Fig. 15: SISTO-C
HV.510/.520
MD 40 - MD 115:
Setting the open-position
travel stop

6.2 Operating limits

6.2.1 Pressure/temperature ratings

Table 12: Permissible operating pressure [bar]¹⁴⁾

PN	Material	[C°]							
	Designation	-20 to +50	+100	+110	+120	+130	+140	+150	+160
16	EPDM	16,0	16,0	16,0	16,0	16,0	16,0	-	-
	TFM/EPDM, bonded	16,0	16,0	16,0	16,0	16,0	16,0	-	-
	TFM/EPDM, 2-piece	16,0	16,0	16,0	16,0	16,0	16,0	14,0	12,0

6.3 Shutdown

6.3.1 Measures to be taken for shutdown

During prolonged shutdown periods, ensure that the following conditions are met:

1. Drain fluids which change their physical condition due to changes in concentration, polymerisation, crystallisation, solidification, etc. from the piping.
2. If required, flush the piping with the valves fully opened.

	CAUTION
	<p>Excessively long idle periods Damage to the valve!</p> <p>▷ Check the function by opening and closing the valve at least once or twice a year.</p>



14 Other pressure/temperature ratings are available on request.

7 Servicing/Maintenance

7.1 Safety regulations

The operator ensures that maintenance, inspection and installation are performed by authorised, qualified specialist personnel who are thoroughly familiar with the manual.

All safety information and instructions must be observed. For any queries contact the manufacturer.

	<div style="background-color: #e67e22; color: white; padding: 5px;">! DANGER</div> <p>Valve under pressure</p> <p>Risk of injury! Leakage of hot and/or toxic fluids! Risk of burns!</p> <ul style="list-style-type: none"> ▷ Depressurise the valve and its surrounding system prior to any maintenance work and installation work. ▷ If there is fluid leakage, depressurise the valve. ▷ Allow the valve to cool down until the temperature of the fluid in all valve areas in contact with the fluid is lower than the fluid's vaporisation temperature. ▷ Never vent the valve by undoing the bonnet bolting or the flange bolting between valve and pipe, or by opening the screw plugs. ▷ Use original spare parts and appropriate tools, even in emergencies.
	<div style="background-color: #f1c40f; color: white; padding: 5px;">! WARNING</div> <p>Fluids handled, consumables and supplies which are hot and/or pose a health hazard</p> <p>Risk of injury! Hazard to persons and the environment!</p> <ul style="list-style-type: none"> ▷ Collect and properly dispose of flushing fluid and any residues of the fluid handled. ▷ Wear safety clothing and a protective mask if required. ▷ When draining the fluid take appropriate measures to protect persons and the environment. ▷ Observe all relevant laws. ▷ Decontaminate valves used in fluids posing a health hazard.

Preparing a maintenance schedule is recommended. A regular maintenance schedule will help avoid expensive repairs and contribute to trouble-free, reliable operation of the valve with a minimum of maintenance expenditure and work.



Never use force when dismantling and reassembling the valve.

Original spare parts are only ready for operation following assembly/installation and subsequent shell and leak testing of the valve.

7.2 Servicing/inspection

7.2.1 Maintenance

All components of diaphragm valves and diaphragm valves with pneumatic piston actuator have been designed to be largely maintenance-free. The materials of the sliding parts have been selected to ensure minimum wear.

	<p>NOTE</p> <p>The operator/user is responsible for fixing appropriate inspection intervals and servicing intervals as required by the service conditions of the valve.</p>
	<p>NOTE</p> <p>On diaphragm valves, diaphragm 443 is usually the highest stressed component. Diaphragm 443 is not only subjected to mechanical stress but also to wear caused by the fluid handled.</p> <p>Depending on service conditions and actuation frequency, we recommend checking diaphragm 443 regularly and replacing it if required.</p> <p>Remove the upper valve section from the valve body to check diaphragm 443.</p>

7.2.2 Supervision of operation

To extend the service life take the following measures:

- Checking the function by actuating the valve at least twice a year
- Lubricating the moving parts with appropriate lubricants to DIN 51825 which are suitable for the application of the valve.

	<p>NOTE</p> <p>To maintain functional reliability, new sealing elements must be used when the valve is reassembled.</p> <p>After reassembly and prior to commissioning/start-up, the overhauled valves must be subjected to shell and leak testing to DIN EN 12266-1.</p>
--	--

7.2.3 Moving the diaphragm valve/diaphragm valve with piston actuator into closed position

(The position indicator must be retracted.)

1. **Diaphragm valve:** Turn handwheel 961 clockwise.
2. **Diaphragm valve with pneumatic piston actuator, "fail-open" (OF) and "double-acting" (AZ):** Apply compressed air to the upper control air port.
3. **Diaphragm valve with pneumatic piston actuator, "fail-close" (SF):** Release the piston actuator pressure.



Fig. 16: Moving the diaphragm valve/LAP into closed position

7.2.4 Moving the diaphragm valve/diaphragm valve with piston actuator into open position

(The position indicator must protrude.) (⇒ Fig. 17)

1. **Diaphragm valve:** Turn handwheel 961 counter-clockwise.
2. **Diaphragm valve with pneumatic piston actuator, "fail-close" (SF) and "double-acting actuators" (AZ):** Apply compressed air to the lower control air port.
3. **Diaphragm valve with pneumatic piston actuator, "fail-open" (OF):** Release the piston actuator pressure.



Fig. 17: Moving the diaphragm valve/LAP into open position



Fig. 18: Unscrewing the diaphragm

7.2.5 Replacing the diaphragm

7.2.5.1 Removing the diaphragm

- ✓ The notes and steps in (⇒ Section 7.1, Page 31) have been observed/carried out.
- ✓ The system is unpressurised; it has been drained and cleaned.
- ✓ Move the upper valve section into open position. (⇒ Section 7.2.4, Page 33) The position indicator must protrude.
 1. Undo hexagon head bolts 901.1 and lift bonnet 165 off the valve body.
 2. Move the upper valve section into closed position (The position indicator must be retracted). (⇒ Section 7.2.3, Page 33)
 3. If diaphragm 443 features a fastening thread, turn it counter-clockwise to unscrew it. (⇒ Fig. 18)
 4. Diaphragm 443 (MD 30 and MD 40) with suffix **N** (button): Simultaneously turn and pull on one side to easily remove diaphragm 443 from compressor 553.

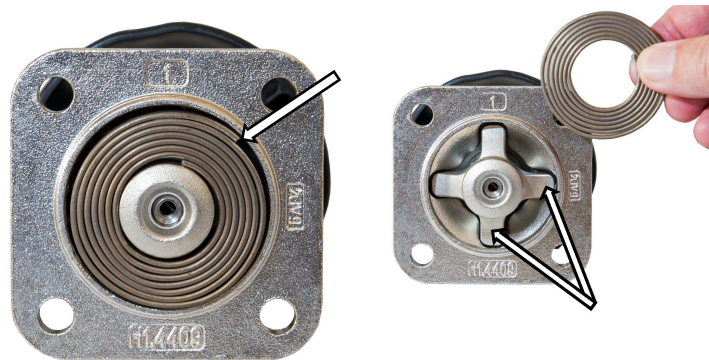

Fig. 19: Support spiral winding end / Compressor ridge



Fig. 20: Screwing in the diaphragm

7.2.5.2 Installing the new diaphragm

- ✓ The contact surfaces for the diaphragm inside body 100 and bonnet 165 must be clean and dry.
 1. Move the upper valve section into closed position. (⇒ Section 7.2.3, Page 33)
 2. **For diaphragm valves with support spiral:** Insert support spiral 951 into bonnet 165. **N.B.:** The last outer winding of support spiral 951 must not end on a ridge of compressor 553. It must be aligned with a bonnet bolt hole. (⇒ Fig. 19)
 3. Remove any protection from the grub screw fastening diaphragm 443.
 4. Screw in new diaphragm 443 until it rests against compressor 553, then back it off a maximum of 180° to ensure it is correctly aligned. (⇒ Fig. 20) **N.B.:** Never use force to screw it in further than the stop!
 5. The bottom of diaphragm 443 is marked with a flow direction arrow. After installation, the actual flow direction of the fluid must match the flow direction arrow on the valve. (⇒ Fig. 22)
 6. **The ridge of the diaphragm must be parallel to the weir of the body.** (⇒ Fig. 21) This requirement must be met for the valve to provide reliable shut-off.
 7. **Diaphragm valve with handwheel:** Move the upper valve section into open position until the diaphragm rests against bonnet 165. The position indicator must protrude. **Do not fully open the diaphragm valve!** (⇒ Section 7.2.4, Page 33)
 8. **Diaphragm valve with actuator (SF/OF/AZ):** Move the piston actuator into open position.
 9. Check the position of diaphragm 443.
 10. Place bonnet 165 onto body 100. Tighten fastening bolts 901.1 of bonnet 165 by hand.



Fig. 21: Ridge of the diaphragm and weir of the body



Fig. 22: Flow direction arrow on the bottom

11. **Diaphragm valve with handwheel:** The upper valve section remains open. Tighten hexagon head bolts 901.1 evenly and crosswise (⇒ Fig. 23) in accordance with the tightening torques table. SISTO-C (⇒ Section 7.3, Page 36) /SISTO-B (⇒ Section 7.4, Page 36)
12. **Diaphragm valve with actuator (SF/OF/AZ):** Move the piston actuator into closed position. (⇒ Section 7.2.3, Page 33) Tighten hexagon head bolts 901.1 evenly and crosswise (⇒ Fig. 23) in accordance with the tightening torques table. SISTO-C (⇒ Section 7.3, Page 36) /SISTO-B (⇒ Section 7.4, Page 36)
13. Move the piston actuator back into open position (⇒ Section 7.2.4, Page 33) and re-check the tightening torques of hexagon head bolts 901.1 if necessary.

Observe the tightening torques (⇒ Section 7.3, Page 36) / (⇒ Section 7.4, Page 36) .

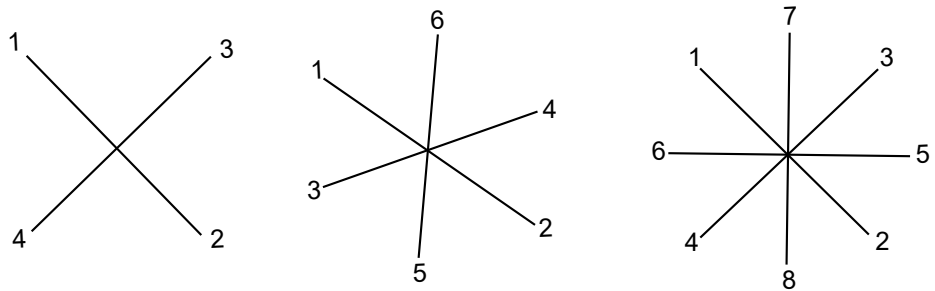

Fig. 23: Tightening the bolts crosswise



Fig. 24: Multi-part diaphragm (TFM/EPDM) with backing ring

7.2.5.3 Installing multi-part diaphragms (TFM/EPDM) with backing ring

Align the metal backing ring used for multi-part diaphragms such that its grooved face rests against the back of the plastic diaphragm. Mounted in this way, the ring's smaller face will point towards the bonnet flange.

7.2.6 Valve reassembly

Valve reassembly is performed in reverse order to dismantling; same procedure as for replacing the diaphragm. (⇒ Section 7.2.5, Page 34)

	NOTE
<p>To maintain functional reliability, new sealing elements must be used when the valve is reassembled. After reassembly and prior to commissioning/start-up, the overhauled valves must be subjected to shell and leak testing to DIN EN 12266-1.</p>	

7.3 Tightening torques of SISTO-C

Tightening torques only apply to the valve's temperature range between +5 °C and +40 °C.

Table 13: Tightening torques [Nm] of SISTO-C

Diaphragm	Diaphragm diameter (MD)							
	30	40	65	92	115	168	202	280
EPDM	1,5	3	8	12	14	18	32	40
TFM sheet, bonded	1,5	3,5	8	12	18	-	-	-
TFM (2-piece)	2	4	10	18	30	40	60	75



7.4 Tightening torques of SISTO-B

Tightening torques only apply to the valve's temperature range between +5 °C and +40 °C.

Table 14: Tightening torques [Nm] of SISTO-B

Diaphragm	Diaphragm length (ML)												
	32	46	52	58	67	82	90	108	132	158	226	260	304
EPDM	0,8	3,5	2,5	6	8	12	15	25	30	45	30	35	50
TFM sheet, bonded	1	4	2,5	7	9	13	17	26	-	-	-	-	-
TFM (2-piece)	-	6	-	8	10	15	18	28	35	50	35	40	55

8 Trouble-shooting

	 WARNING
	<p>Improper remedial work on the valve</p> <p>Risk of injury!</p> <ul style="list-style-type: none"> ▸ For any work performed in order to remedy faults on the valve observe the relevant information given in this operating manual and/or the product literature provided by the accessories manufacturers.

Diaphragm valves and diaphragm valves with pneumatic piston actuator made by SISTO Armaturen feature a robust design. Nevertheless, malfunctions e.g. caused by incorrect operation, lack of maintenance or improper use cannot be ruled out completely. Have all repair and maintenance work carried out by competent personnel using suitable tools and original spare parts.

If problems occur that are not described in the following table, consultation with the SISTO Armaturen service is required.

Table 15: Trouble-shooting

Problem	Possible cause	Remedy
Leakage at the mating flanges	<ul style="list-style-type: none"> ▪ Contaminated fluid or solids in the fluid ▪ Erosion, corrosion, abrasion ▪ Excessive loads from piping forces or thermal stresses 	<ol style="list-style-type: none"> 1. Dismantle. 2. Clean. 3. Replace the sealing elements.
Leakage at the bolting of body 100 and bonnet 165.	<ul style="list-style-type: none"> ▪ Compressive-stress relaxation ▪ Sealing element has settled as a result of high temperature fluctuations. ▪ Impermissible pressure loads ▪ Poor maintenance ▪ Insufficient resistance of the sealing elements to temperature and fluid handled 	Re-tighten hexagon head bolts 901.1 as described in (⇒ Section 7.3, Page 36) / (⇒ Section 7.4, Page 36) .
Leakage at the stem neck or leakage indication hole caused by diaphragm rupture	<ul style="list-style-type: none"> ▪ Rupture of diaphragm 443 	Replace defective diaphragm 443. (⇒ Section 7.2.5, Page 34)
Leakage at seat/disc interface	<ul style="list-style-type: none"> ▪ Foreign matter at the weir 	Remove foreign matter from the weir and replace diaphragm 443 if necessary. (⇒ Section 7.2.5, Page 34)
	<ul style="list-style-type: none"> ▪ Foreign matter in or on the diaphragm lip ▪ Damage to the diaphragm lip 	Remove foreign matter and replace diaphragm 443 if necessary. (⇒ Section 7.2.5, Page 34)
	<ul style="list-style-type: none"> ▪ Stop nut 920 for closed position incorrectly adjusted 	Re-adjust stop nut 920 or replace diaphragm 443 if necessary. (⇒ Section 7.2.5, Page 34)

9 Related Documents

9.1 General assembly drawings with list of components, SISTO-C

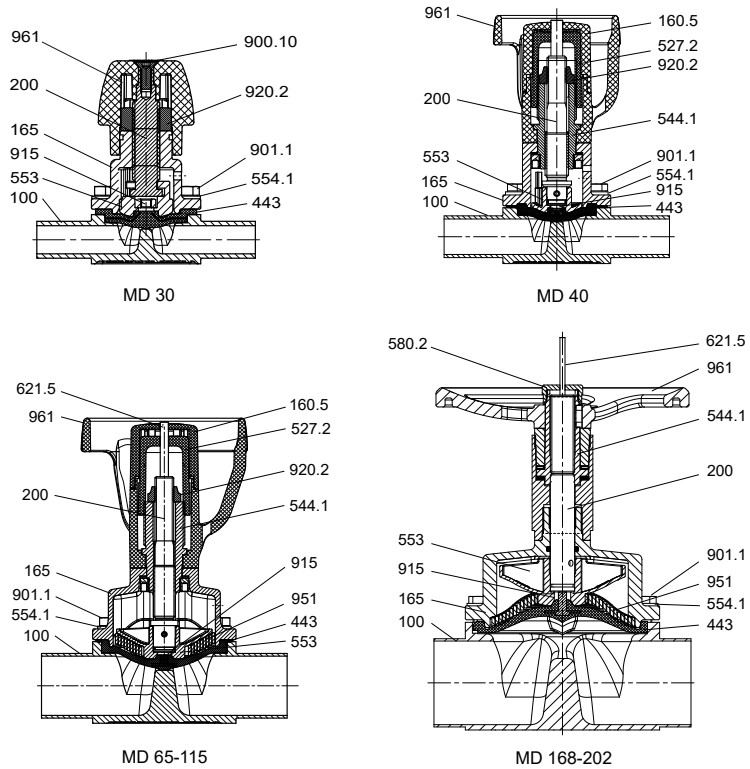

Fig. 25: SISTO-C HV.510/.520

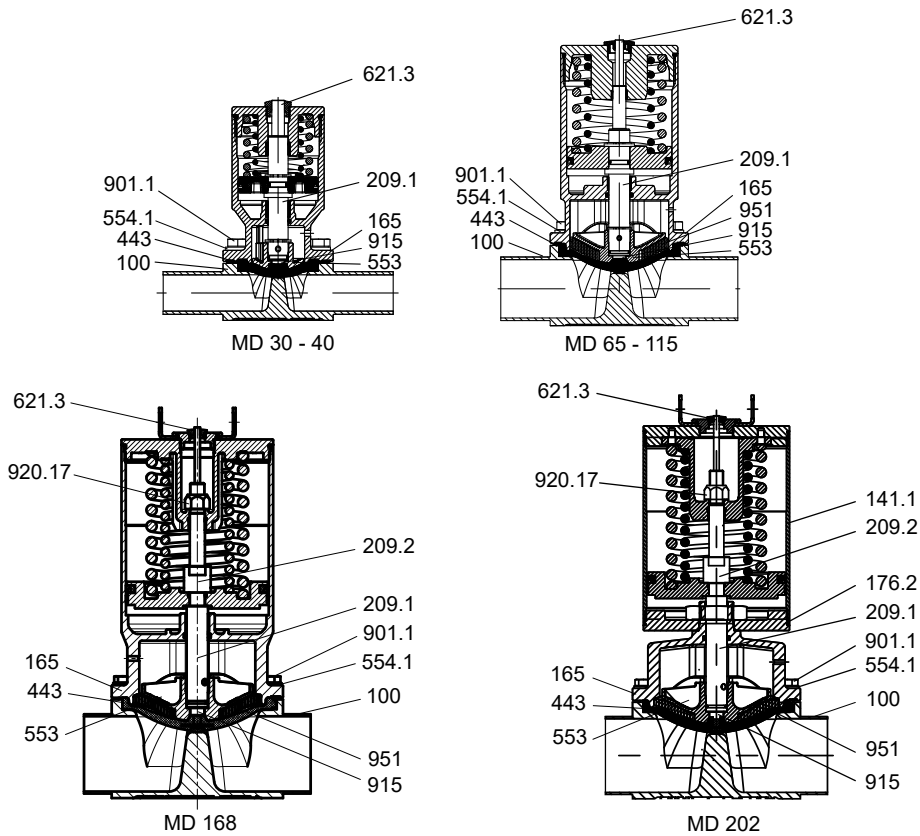

Fig. 26: SISTO-C LAP.520 (illustration of pneumatic piston actuator SF)

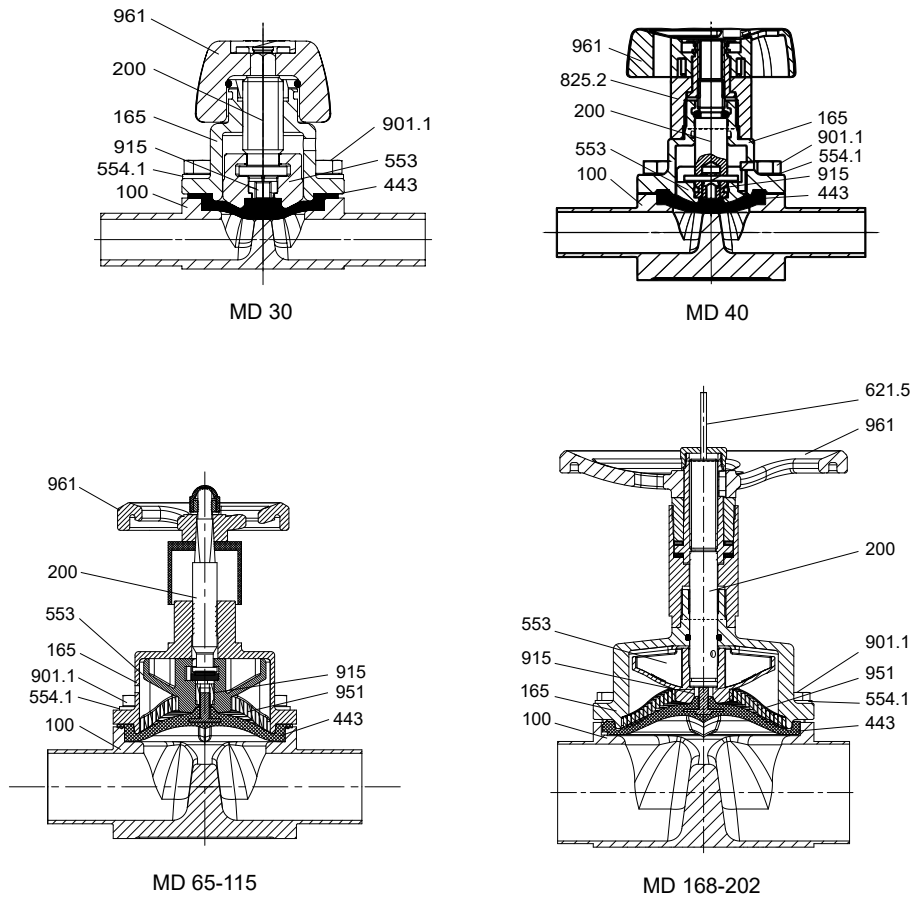

Fig. 27: SISTO-C HV

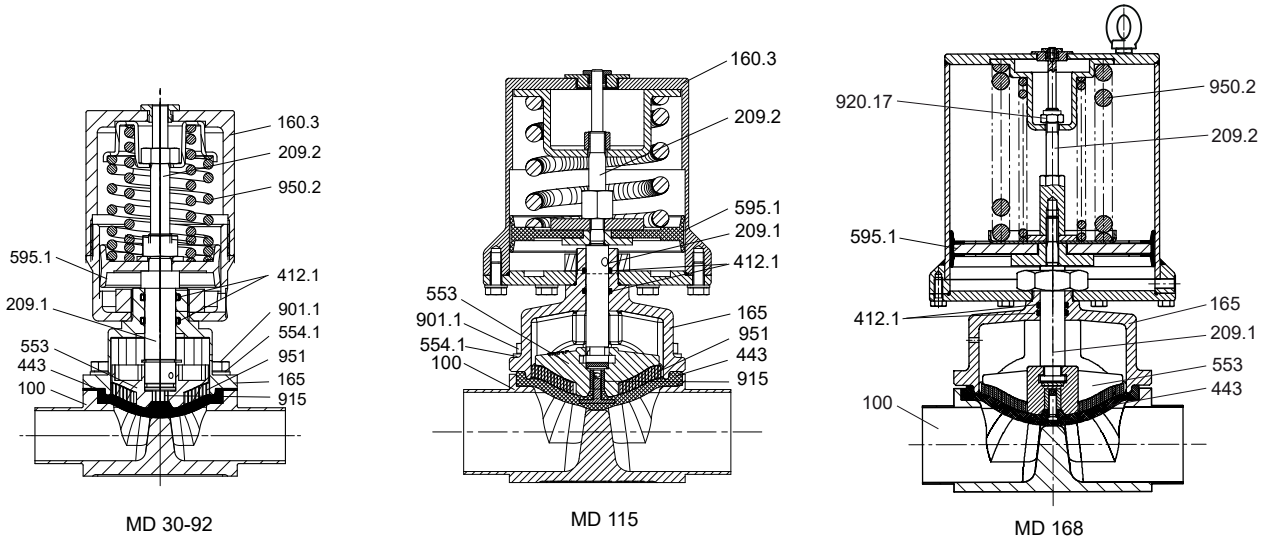

Fig. 28: SISTO-C LAP

Table 16: Overview of available materials

Part No.	Description	Material	Material number	Note
100	Body	X2CrNiMo18-14-3	1.4435/316L	Forged
132.2	Intermediate piece	X2CrNiMo17-12-2	1.4404	-
141.1	Cylinder	X5CrNi18-10 / X6CrNiTi18-10	1.4301/1.4541	MD 168 - MD 202 Also in aluminium, hard anodised
160.5	Handwheel cover	PA66-GF30	-	-
160.9	Bearing cover	X2CrNiMo17-12-2	1.4404	-

0570.822/05-EN

Part No.	Description	Material	Material number	Note
165	Bonnet	GX2CrNiMo19-11-2	1.4409	-
176.2	Bottom end cap	X2CrNiMo17-12-2	1.4404	-
200	Stem	X2CrNiMo17-12-2 X8CrNiS18-9	1.4404/1.4305	MD 30 = 1.4404 Kolsterised
209.1	Lower piston rod	X8CrNiS18-9	1.4305	-
209.2	Upper piston rod	X8CrNiS18-9	1.4305	-
443 ¹⁵⁾	Diaphragm	SISTO-AseptiXX EPDM	-	FDA, CFR 21, Section 177.2600 EG 1935/2004
527.2	Locating sleeve	PA66-GF30	-	-
544.1	Threaded bush	SoMs59	-	-
553	Compressor	GX2CrNiMo19-11-2	1.4409	-
554.1	Washer	A2	-	-
580.2	Cap	X2CrNiMo17-12-2	1.4404	-
595.1 ^{15) 16)}	Piston assembly	St/NBR	-	-
621.3	Position indicator	PA	-	-
621.5	Position indicator	PA	-	-
900.10	Bolt/screw	A2	-	-
901.1	Hexagon head bolt	A2-70	-	-
915	Floating nut	A2	-	-
920.2	Nut	A2	-	-
920.17	Nut	A2	-	-
950.2	Spring	Spring steel	-	-
951	Support spiral	X5CrNi18-10	1.4301	From MD 65
961	Handwheel	PA66-GF30	-	MD 30 - MD 115
		GX2CrNiMo19-11-2	1.4409	-

¹⁵ Recommended spare parts

¹⁶ We recommend having these parts replaced in our factory.

9.2 General assembly drawings with list of components, SISTO-B

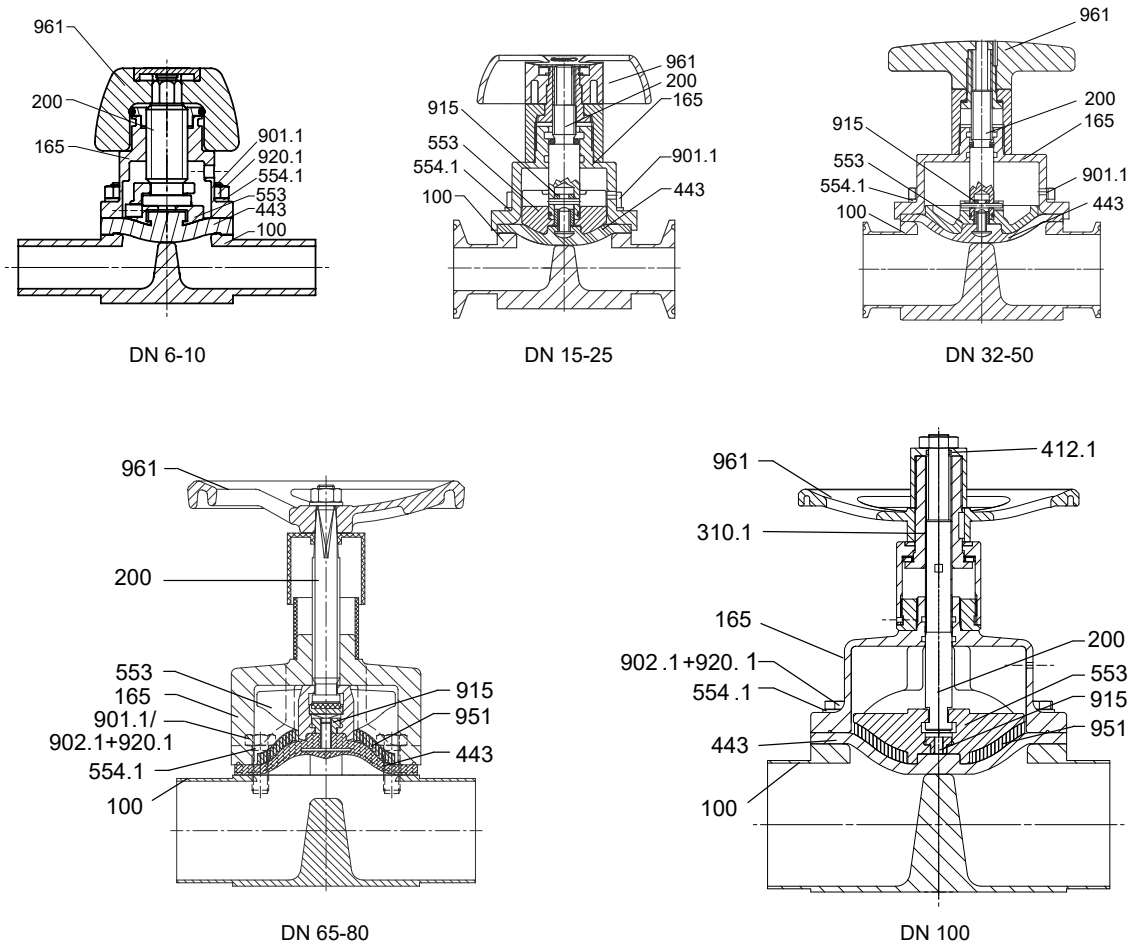

Fig. 29: SISTO-B manually operated valve

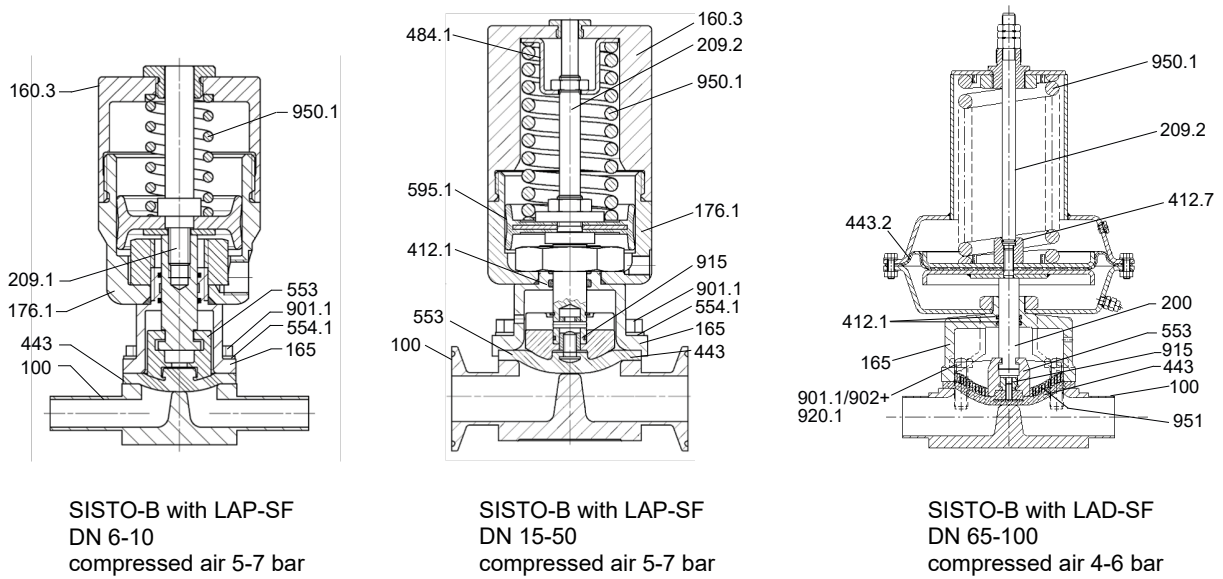

Fig. 30: SISTO-B with mounted LAP-SF / LAD-SF

0570.822/05-EN

Table 17: Overview of available materials

Part No.	Description	Material number	Note
100	Body	316L/1.4435	Precision (investment) casting (1.4435) / forged
160.3	Cover	PA6GF30	-
165	Bonnet	316L	DN 6 - DN 50, DN 100 = precision (investment) casting 1.4409
		JS-1025 / PA coating	DN 65 - DN 80
200	Stem	1.4104	-
209.1	Lower piston rod	1.4404	-
209.2	Upper piston rod	1.4404	-
310.1 ¹⁷⁾ 18)	Plain bearing	Brass	-
412.1 ¹⁷⁾ 18)	O-ring	EPDM	-
		FPM/FKM	-
412.7 ¹⁷⁾ 18)	O-ring	NBR	-
443 ¹⁷⁾	Diaphragm	EPDM	-
443.2 ¹⁷⁾	Diaphragm	NBR	-
484.1	Spring plate	Galvanised steel	-
553	Compressor	316L	DN 6 - DN 50, DN 100 = precision (investment) casting 1.4409
		JL-1040	DN 65 - DN 80
554.1	Washer	A2	-
595.1 ¹⁷⁾ 18)	Piston assembly	St/NBR	-
901.1	Hexagon head bolt	A2-70	-
902	Stud	A2-70	-
902.1	Stud	A2-70	-
915	Floating nut	A2	-
920.1	Nut	A2	-
950.1	Spring	1.4310	-
951	Support spiral	Galvanised steel	DN 65 - DN 80
		1.4301	DN 100
961	Handwheel	PA6GF30	DN 6 - DN 50
		JL-1030 / PA coating	DN 65 - DN 100

¹⁷ Recommended spare parts

¹⁸ We recommend having these parts replaced in our factory.

9.3 Dimensions to ISO – precision (investment) cast body

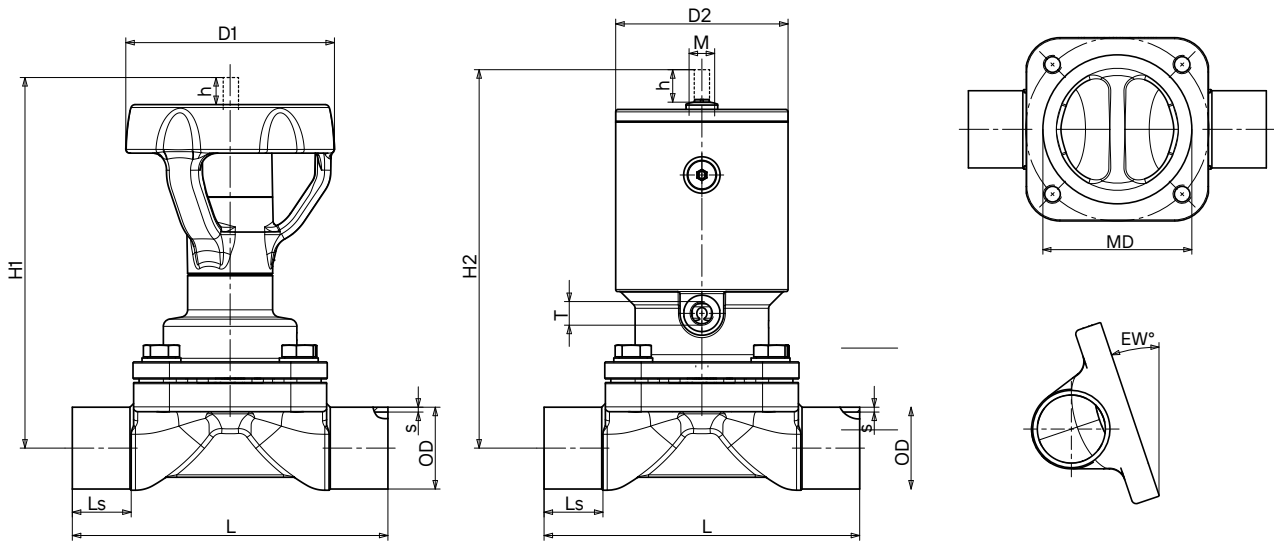

Fig. 31: Dimensions to ISO

Table 18: Dimensions to ISO (precision (investment) cast body)

DN ⁽²¹⁾	Inch	MD	h [mm]	EW [°] ⁽²²⁾	Manually operated valve ⁽¹⁹⁾			Piston actuator ⁽²⁰⁾				Butt weld ends to DIN 11866-B (ISO 4200)			K _{vs} value [m ³ /h]				
					H1 [mm]	D1 [mm]	[kg]	H2 [mm]	D2 [mm]	[kg]	T	M	L [mm]	Ls [mm]		OD × s [mm]			
8	5/16	30	5	21,0	71	35	0,3	90	41	0,6	M 5	M 12 × 1	80	20,0	13,5 × 1,6	3,0			
10	3/8	40	7	25,3	117	66	0,7	104	46	0,7	G 1/8		115	30,0	17,2 × 1,6	6,1			
15	1/2			14,3	120			107								21,3 × 1,6	7,3		
20	3/4	65	13	27,9	150	88	1,3	153	71	2,2	M 18 × 1	M 12 × 1	130	25,0	26,9 × 1,6	25,8			
25	1			18,7	153		1,4	156		2,3								33,7 × 2,0	29,7
32	1 1/4	92	21	21,7	220	125	3,3	212	89	5,0								42,4 × 2,0	60,0
40	1 1/2			15,2	223		3,4	215		5,1					48,3 × 2,0	65,0			
50	2	115	24	16,8	239		5,0	250	110	8,2			190	32,5	60,3 × 2,0	102,0			

0570.8.22/05-EN

19 Variant HV.510 for MD 30 - MD 115

20 Variant LAP.520 for MD 30 - MD 115

21 Smaller and larger nominal sizes available on request

22 Maximum tolerance -3°

9.4 Dimensions to OD ASME BPE – precision (investment) cast body

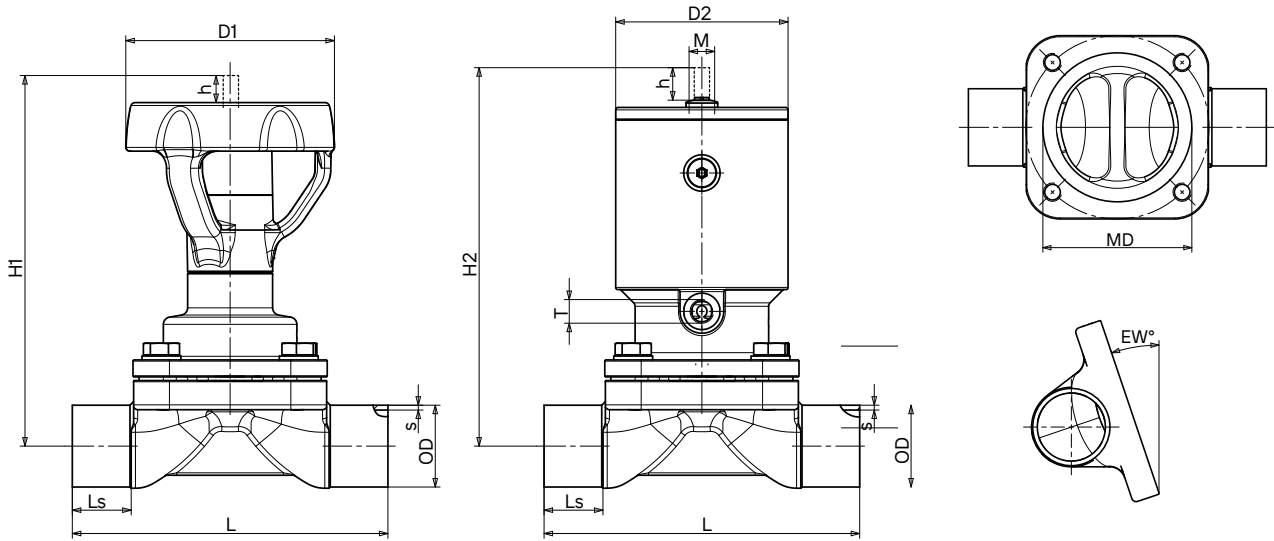

Fig. 32: Dimensions to OD ASME BPE

Table 19: Dimensions to OD ASME BPE (precision (investment) cast body)

DN ⁽²⁵⁾	Inch	MD	h [mm]	EW [°] ⁽²⁶⁾	Manually operated valve ⁽²³⁾			Piston actuator ⁽²⁴⁾					Butt weld ends to DIN 11866-B (ISO 4200)			K _{vs} value [m ³ /h]
					H1 [mm]	D1 [mm]	[kg]	H2 [mm]	D2 [mm]	[kg]	T	M	L [mm]	Ls [mm]	OD × s [mm]	
15	1/2	30	5	23,5	71	35	0,3	90	41	0,5	M 5	M 12 × 1	80	20,0	12,7 × 1,65	2,8
20	3/4	40	7	20,6	118	66	0,7	105	45	0,7	G 1/8		115	30,0	19,05 × 1,65	6,9
25	1	65	13	30,4	150	88	1,3	153	71	2,2		M 18 × 1	130	25,0	25,4 × 1,65	24,1
40	1 1/2			11,4	156		1,4	159	89	2,3						38,1 × 1,65
50	2	92	21	11,6	226	125	3,4	218		5,1		180	37,5	50,8 × 1,65	62,0	
65	2 1/2	115	24	13,8	241		5,0	252	110	8,2		190	32,5	63,5 × 1,65	93,0	

23 Variant HV.510 for MD 30 - MD 115

24 Variant LAP.520 for MD 30 - MD 115

25 Smaller and larger nominal sizes available on request

26 Maximum tolerance -3°

9.5 Dimensions to DIN – forged body

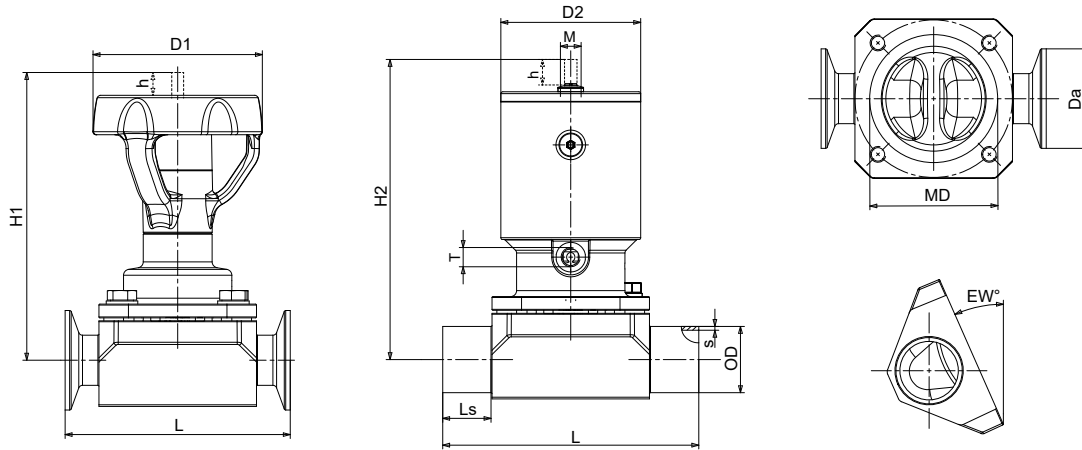

Fig. 33: Dimensions to DIN

Table 20: Dimensions to DIN (forged body)

DN ⁽²⁹⁾	Inch	MD	h [mm]	EW [°] ⁽³⁰⁾	Manually operated valve ⁽²⁷⁾			Piston actuator ⁽²⁸⁾				Butt weld ends to DIN 11866-A			Clamps to DIN 32676-A (DIN 11866-A)		K _{vs} value [m ³ /h]			
					H1 [mm]	D1 [mm]	[kg]	H2 [mm]	D2 [mm]	[kg]	T	M	L [mm]	Ls [mm]	OD × s [mm]	L [mm]		Da [mm]		
Standard DN/MD combination																				
6	1/4	30	5	41,2	68	35	0,4	87	41	0,6	M5	M12×1	80	20,0	8 × 1,0	63,5	25,0	1,1		
8	5/16			34,6	68			87									10 × 1,0			1,8
10	3/8			24,0	69			88									13 × 1,5		34,0	2,1
15	1/2	40	7	21,7	116	66	0,9	103	46	0,9	M5	M12×1	115	30,0	19 × 1,5	88,9	34,0	5,0		
20	3/4	65	13	34,6	146	88	2,0	149	71	2,9					130	25,0	23 × 1,5	101,6		11,8
25	1			24,1	148			151									29 × 1,5	114,3	50,5	16,5
32	1 1/4	92	21	31,3	215	125	4,6	207	89	6,3	G 1/8	M18×1	180	37,5	35 × 1,5	139,7	50,5	34,0		
40	1 1/2			24,7	216			208									41 × 1,5			42,5
50	2	115	24	21,7	231	125	7,1	242	110	10,3					190	32,5	53 × 1,5	158,8	64,0	65,0
65	2 1/2	168	40	31,0	327	250	23,8	396	170	30,7	G 1/8	M18×1	254	31,0	70 × 2,0	-	-	137,0		
80	3			21,0	336			405		30,0							85 × 2,0	-	-	156,0
100	4	202	55	20,0	377	250	37,7	501	210	59,3					305	37,5	104 × 2,0	-	-	245,0
125	5			8,8	392		49,7	516		71,3			356	63,0	129 × 2,0	-	-	230,0		
150	6	280	80	17,6	512	400	97,0	⁻³¹⁾					414	50,0	154 × 2,0	-	-	490,0		
200	8			2,4	536		114,0	⁻³¹⁾					521	103,5	204 × 2,0	-	-	500,0		
Compact DN/MD combination																				
20	3/4	40	7	9,6	120	66	1,0	107	46	1,0	M5	M12×1	115	30,0	23 × 1,5	-	-	4,4		
32	1 1/4	65	13	12,2	154	88	2,1	157	71	3,0					140	30,0	35 × 1,5	-	-	15,4
50	2	92	21	10,0	226	125	5,0	218	89	6,7	G 1/8	M18×1	190	42,5	53 × 1,5	-	-	42,4		
65	2 1/2	115	24	7,0	241	125	8,1	252	110	11,3					200	37,5	70 × 2,0	-	-	65,0
100	4	168	40	10,7	351	250	30,9	439	170	34,7					305	56,5	104 × 2,0	-	-	143,0

0570.8.22/05-EN

27 Variant HV.510 for MD 30-MD 115, variant HV.520 for MD 168-MD 202

28 Variant LAP.520 for MD 30 - MD 202

29 Smaller and larger nominal sizes available on request

30 Maximum tolerance -3 °

31 Design as per customer specifications

9.6 Dimensions to ISO – forged body

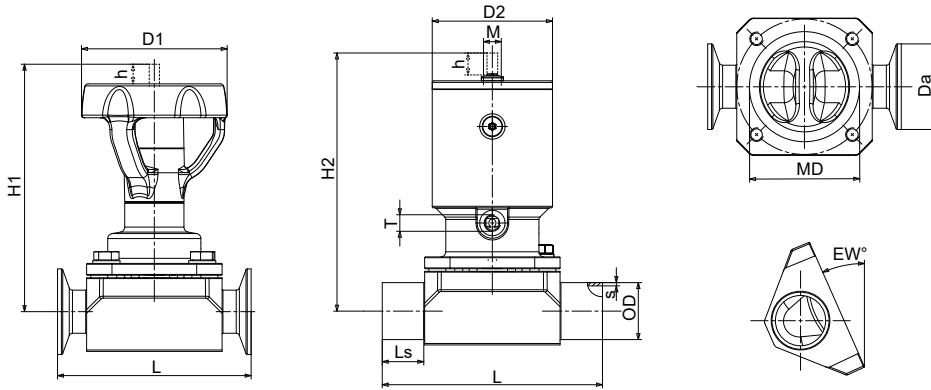

Fig. 34: Dimensions to ISO

Table 21: Dimensions to ISO (forged body)

DN ⁽³⁴⁾	Inch	MD	h [mm]	Maximale Toleranz [°] -3° ⁽³⁵⁾	Manually operated valve ⁽³²⁾			Piston actuator ⁽³³⁾				Butt weld ends to DIN 11866-B (ISO 4200)			Clamps to DIN 32676-B (ISO 4200)		K _{vs} value [m ³ /h]	
					H1 [mm]	D1 [mm]	[kg]	H2 [mm]	D2 [mm]	[kg]	T	M	L [mm]	Ls [mm]	OD × s [mm]	L [mm]		Da [mm]
Standard DN/MD combination																		
6	1/4	30	5	38,0	68	35	0,4	87	41	0,6	M 5	M 12×1	80	20,0	10,2 × 1,6	63,5	25,0	1,5
8	5/16			23,0	69			88									13,5 × 1,6	
10	3/8	40	7	27,7	115	66	0,9	102	46	0,9	M 5	M 12×1	115	30,0	17,2 × 1,6	88,9	25,0	4,5
15	1/2			15,7	117			104									21,3 × 1,6	
20	3/4	65	13	27,1	148	88	2,0	151	71	2,9	M 5	M 12×1	130	25,0	26,9 × 1,6	101,6	50,5	14,7
25	1			17,7	150			153									33,7 × 2,0	114,3
32	1 1/4	92	21	24,4	216	125	4,6	208	89	6,3	M 5	M 12×1	180	37,5	42,4 × 2,0	139,7	64,0	43,0
40	1 1/2			17,1	219			211									48,3 × 2,0	
50	2	115	24	15,6	234	125	7,1	245	110	10,3	M 5	M 12×1	190	32,5	60,3 × 2,0	158,8	77,5	69,0
65	2 1/2	168	40	27,0	330	250	23,8	399	170	30,7			G 1/8	M 18×1	254	31,0	76,1 × 2,0	-
80	3			19,6	336		22,8	405		30,0							88,9 × 2,3	-
100	4	202	55	15,3	382	250	37,7	506	210	59,3	G 1/8	M 18×1	305	37,5	114,3 × 2,3	-	-	255,0
125	5			5,4	392		47,7	516		69,3					356	63,0	139,7 × 2,6	-
150	6	280	80	13,7	518	400	92,0	- ⁽³⁶⁾			G 1/8	M 18×1	414	50,0	168,3 × 2,6	-	-	500,0
200	8			1,3	543		111,0	- ⁽³⁶⁾							521	103,5	219,1 × 2,6	-
Compact DN/MD combination																		
10	3/8	30	5	7,7	72	35	0,4	91	41	0,6	G 1/8	M 12×1	80	20,0	17,2 × 1,6	-	-	2,2
20	3/4	40	7	2,8	120	66	1,0	107	46	1,0					115	30,0	26,9 × 1,6	-
32	1 1/4	65	13	4,2	154	88	2,6	157	71	3,5			140	30,0	42,4 × 2,0	-	-	17,5

32 Smaller and larger nominal sizes available on request

33 Maximum tolerance -3°

34 Variant HV.510 for MD 30-MD 115, variant HV.520 for MD 168-MD 202

35 Variant LAP.520 for MD 30 - MD 202

36 Design as per customer specifications

DN ³²⁾	Inch	MD	h [mm]	33) [°] Maximale Toleranz -3°	Manually operated valve ³⁴⁾			Piston actuator ³⁵⁾				Butt weld ends to DIN 11866-B (ISO 4200)			Clamps to DIN 32676-B (ISO 4200)		K _{vs} value [m ³ /h]
					H1 [mm]	D1 [mm]	[kg]	H2 [mm]	D2 [mm]	[kg]	T	M	L [mm]	Ls [mm]	OD × s [mm]	L [mm]	
50	2	92	21	4,9	226	125	6,5	218	89	8,2	G ¹ / ₈ M18×1	190	42,5	60,3 × 2,0	-	-	45,7
65	2 1/2	115	24	2,7	241	125	7,6	252	110	10,8		200	37,5	76,1 × 2,0	-	-	67,0
100	4	168	40	6,3	351	250	29,8	420	170	36,7		305	56,5	114,3 × 2,3	-	-	157,0

9.7 Dimensions to OD ASME BPE – forged body

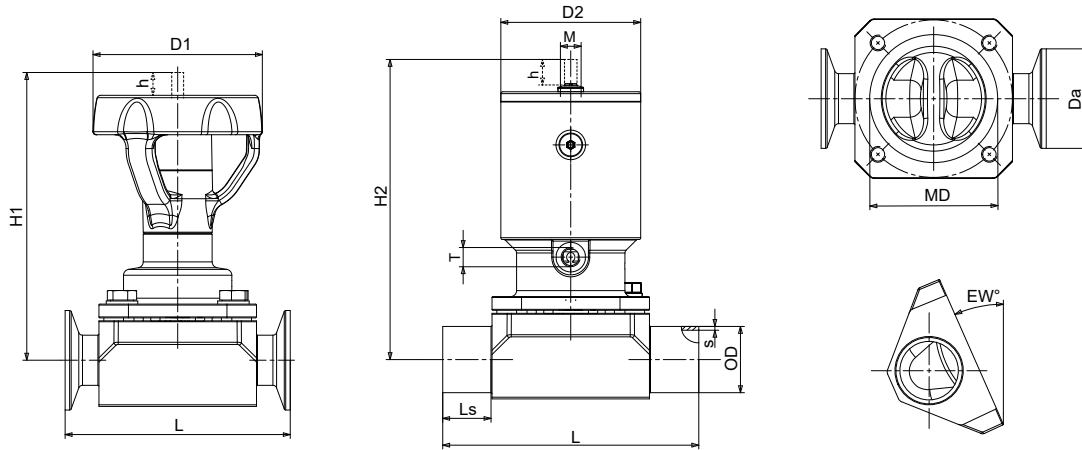

Fig. 35: Dimensions to OD ASME BPE

Table 22: Dimensions to OD ASME BPE (forged body)

DN ³⁹⁾	Inch	MD	h [mm]	40) [°] Maximale Toleranz -3°	Manually operated valve ³⁷⁾			Piston actuator ³⁸⁾				Butt weld ends to OD ASME BPE			Clamps to DIN 32676-C (OD ASME BPE)		K _{vs} value [m ³ /h]	
					H1 [mm]	D1 [mm]	[kg]	H2 [mm]	D2 [mm]	[kg]	T	M	L [mm]	Ls [mm]	OD × s [mm]	L [mm]		Da [mm]
Standard DN/MD combination																		
6	1/4	30	5	45,8	68	35	0,4	87	41	0,6	M 5	M 12×1	80	20,0	6,35 × 0,89	63,5	25,0	0,6
10	3/8			35,5	68			87									9,53 × 0,89	
15	1/2			26,0	69			88							12,7 × 1,65			2,1
15	1/2	40	7	37,3	115	66	0,9	102	46	0,9	M 5	M 12×1	115	30,0	12,7 × 1,65	88,9	25,0	2,6
20	3/4			22,2	116			103									19,05 × 1,65	101,6
25	1	65	13	31,8	146	88	2,0	149	71	2,9	M 5	M 12×1	130	25,0	25,4 × 1,65	114,3	50,5	13,8
40	1 1/2	92	21	28,8	215	125	4,6	207	89	6,3					180	37,5	38,1 × 1,65	139,7
50	2	115	24	23,5	231	125	7,1	242	110	10,3	G 1/8	M 18×1	190	32,5	50,8 × 1,65	158,8	64,0	62,0
65	2 1/2			12,3	236		6,4	247		9,6							63,5 × 1,65	193,8
80	3	168	40	26,7	330	250	22,8	399	170	29,7	G 1/8	M 18×1	254	31,0	76,2 × 1,65	222,3	91,0	151,0
100	4	202	55	20,9	377	250	37,7	501	210	59,3					305	37,5	101,6 × 2,11	292,1
150	6	280	80	18,8	512	400	93,4	- ⁴¹⁾					414	50,0	152,4 × 2,77	-	-	490,0
Compact DN/MD combination																		
50	2	92	21	12,0	226	125	6,5	218	89	8,2	G 1/8	M 18×1	190	42,5	50,8 × 1,65	-	-	42,4
80	3	115	24	2,1	242	125	7,6	252	110	10,8					200	37,5	76,2 × 1,65	-
100	4	168	40	11,9	351	250	30,9	414	170	35,0			305	56,5	101,6 × 2,11	-	-	143,0

37 Variant HV.510 for MD 30-MD 115, variant HV.520 for MD 168-MD 202

38 Variant LAP.520 for MD 30 - MD 202

39 Smaller and larger nominal sizes available on request

40 Maximum tolerance -3°

41 Design as per customer specifications

9.8 Dimensions to SMS – forged body

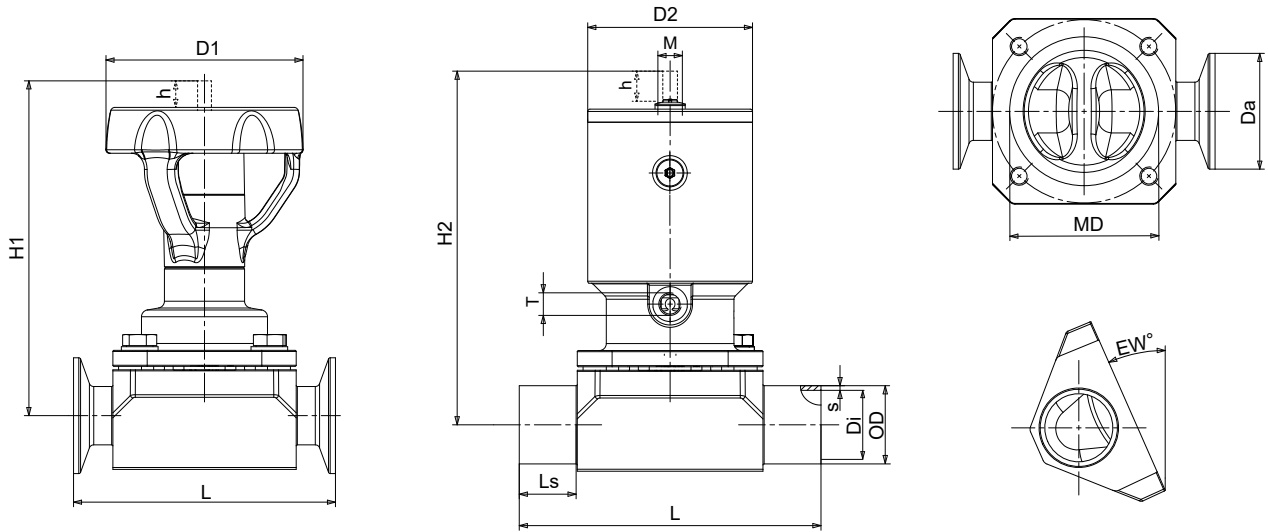

Fig. 36: Dimensions to SMS

Table 23: Dimensions and weights to SMS (forged body)

DN ⁽⁴⁴⁾	Inch	MD	h [mm]	45) [°] Maximale Toleranz -3°	Manually operated valve ⁽⁴²⁾			Piston actuator ⁽⁴³⁾				Butt weld ends to SMS 3008			Clamps to DIN 32676 (SMS 3008)			K _{vs} value [m ³ /h]		
					H1 [mm]	D1 [mm]	[kg]	H2 [mm]	D2 [mm]	[kg]	T	M	L [mm]	Ls [mm]	OD × s [mm]	L [mm]	Da [mm]		Di [mm]	
Standard DN/MD combination																				
10	3/8	30	5	24,0	69	35	0,4	88	41	0,6	M 5	M 12×1	80	20,0	12 × 1,0	63,5	25,0	10,0	2,1	
15	1/2	40	7	21,7	116	66	0,9	103	46	0,9			115	30,0	18 × 1,0	88,9	25,0	16,0	5,0	
25	1	65	13	31,1	146	88	2,0	149	71	2,9	M 12×1	M 18×1	130	25,0	25 × 1,2	114,3	50,5	22,6	13,8	
40	1 1/2	92	21	26,9	216	125	4,6	208	89	6,3			180	37,5	38 × 1,2	139,7	50,5	35,6	39,0	
50	2	115	24	22,7	231	250	7,1	242	110	10,3	G 1/8	M 18×1	190	32,5	51 × 1,2	158,8	64,0	48,6	62,0	
65	2 1/2			12,2	236		6,4	247		9,6					63,5 × 1,6	193,8	77,5	60,3	71,0	
80	3	168	40	26,7	330	22,8	399	170	29,7			254	30,0	76,1 × 1,6	222,3	91,0	72,9	151,0		
100	4	202	55	20,8	377	37,7	501	210	59,3			G 1/8	M 18×1	305	37,5	101,6 × 2,0	292,1	119,0	97,6	237,0
Compact DN/MD combination																				
50	2	92	21	11,2	226	125	4,9	218	89	6,6	G 1/8	M 18×1	190	42,5	51,0 × 1,2	-	-	-	42,4	
80	3	115	24	2,1	242	125	7,5	253	110	10,7			200	37,5	76,1 × 1,6	-	-	-	67,0	
100	4	168	40	11,8	345	250	28,1	414	170	35,0	G 1/8	M 18×1	305	56,5	101,6 × 2,0	-	-	-	143,0	

0570.8.22/05-EN

42 Variant HV.510 for MD 30-MD 115, variant HV.520 for MD 168-MD 202

43 Variant LAP.520 for MD 30 - MD 202

44 Smaller and larger nominal sizes available on request

45 Maximum tolerance -3°

9.9 Specifications

Butt weld ends:	DIN 11866 Series A (DIN 11850) DIN 11866 Series B (DIN EN ISO 1127/ISO 4200) DIN 11866 Series C (OD ASME BPE) SMS 3008 JIS-G 3447
Clamps:	DIN 32676 ASME BPE SMS 3017 JIS-G 3447
Marking:	DIN EN 19 (ISO 5209) ASME BPE

10 Mounting / Installation Accessories and Variants

10.1 General description

If a SISTO-C accessory has been ordered as a unit together with a diaphragm valve, the corresponding accessory will be supplied mounted on the diaphragm valve.

In the case of any deviations contact SISTO Armaturen.

10.2 Mechanical open-position travel stop

For use with SISTO-C diaphragm valves with pneumatic piston actuator

- SISTO-C LAP.520 SF/OF/AZ MD 30 - MD 115
- SISTO-C LAP.520 SF/OF/AZ MD 168 - MD 202

Purpose

Travel stop for diaphragm valves with pneumatic piston actuator in open position.

Mounting

For a correct setting of the travel stop the upper section of the diaphragm valve must be mounted on the body as described in the operating manual.



Fig. 37: Open-position travel stop

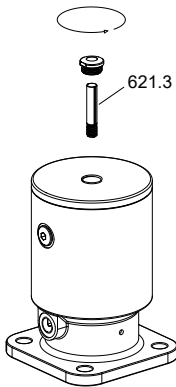

Fig. 38: Removing the cap and position indicator LAP.520

Retrofitting the travel stop:

1. Remove the plastic cap of the piston actuator with an open-ended spanner (WAF13/WAF21). Unscrew and remove position indicator 621.3.
2. Screw position indicator 621.4 of the travel stop into the piston rod of the piston actuator.
3. Screw travel stop assembly 544.2/904.1 into the thread of the piston actuator. Tighten it to the specified tightening torque (⇒ Table 24) .

Table 24: Tightening torque of the open-position travel stop

Diaphragm diameter (MD)	[Nm]
30-115	50
168-202	100

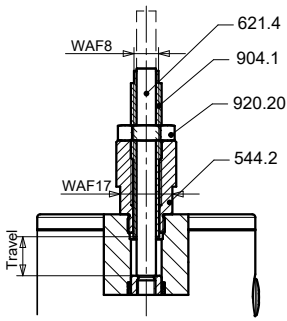

Fig. 39: Open-position travel stop MD 30-65

Setting the travel stop:

1. Move the piston actuator into closed position.
2. Undo nut 920.20.
3. Screw grub screw 904.1 into the piston actuator as far as it will go. The set valve travel equals 0 mm when the piston actuator is mounted on a body with diaphragm.
4. Set the required valve travel by backing off the grub screw (⇒ Table 25) . (Intermediate values can be derived by linear interpolation.) Finally, check the final value of valve travel.
5. Holding grub screw 904.1 in place, tighten nut 920.20 to the specified tightening torque (⇒ Table 24) .

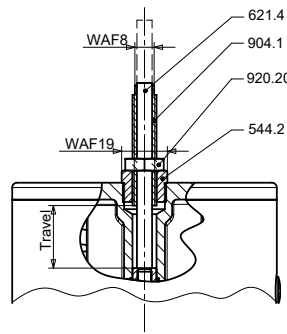

Fig. 40: Open-position travel stop MD 92-115

Table 25: Open-position valve travel settings LAP.520 MD 30-MD 202

MD	Maximum valve travel [mm]	Number of turns from closed position				
		Travel = 100 %	Travel = 80 %	Travel = 60 %	Travel = 40 %	Travel = 20 %
30	5	3,3	2,7	2,0	1,3	0,7
40	7	4,7	3,7	2,8	1,9	0,9
65	13	8,7	6,9	5,2	3,5	1,7
92	21	14,0	11,2	8,4	5,6	2,8
115	24	16,0	12,8	9,6	6,4	3,2
168	45	45,0	36,0	27,0	18,0	9,0
202	60	60,0	48,0	36,0	24,0	12,0

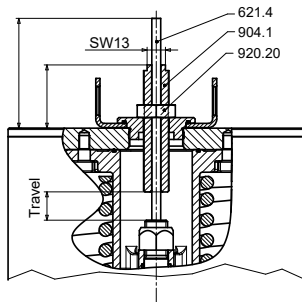

Fig. 41: Open-position travel stop in MD 168 - 202

	NOTE
<p>Position indicator 621.4 of the travel stop is delivered in maximum length and is often not flush with grub screw 904.1 in closed position.</p> <p>If the closed position is to be made more visible: Mark the protruding part of position indicator 621.4 in closed position with a band or pen. The position indicator can be also shortened, so it is flush with grub screw 904.1 in closed position.</p>	



10.3 Mechanical closed-position travel stop

For use with SISTO-C diaphragm valves with pneumatic piston actuator

- SISTO-C LAP.520 SF/OF/AZ MD 30 - MD 115
- SISTO-C LAP.520 SF/OF/AZ MD 168 - MD 202

Purpose

Travel stop for diaphragm valves with pneumatic piston actuator in closed position

	<p>! WARNING</p>
	<p>Without protecting tube risk of crushing injuries by moving parts Risk of injury! ▷ The diaphragm valve must only be operated when protecting tube 141 is fitted.</p>
	<p>NOTE</p>
	<p>The travel stop assembly is not available as a separate item; it can only be obtained in combination with the upper section of the diaphragm valve. It cannot be retrofitted.</p>

Mounting

For a correct setting of the travel stop the upper section of the diaphragm valve must be mounted on the body as described in the operating manual.



Fig. 42: Closed-position travel stop

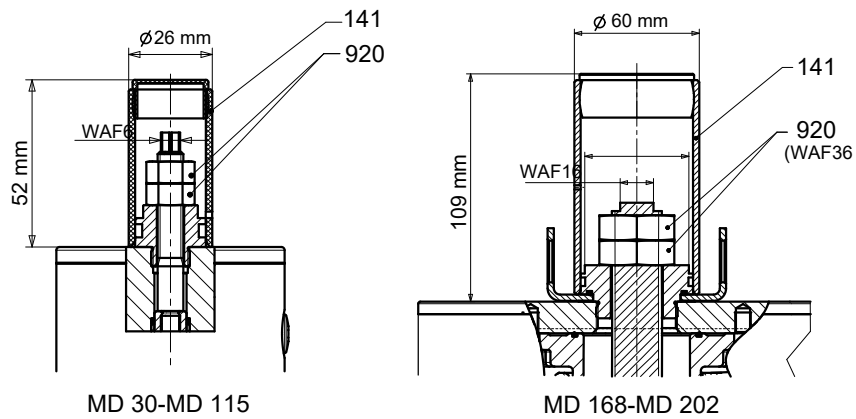

Fig. 43: Closed-position travel stop

Setting the travel stop:

Setting the travel stop

1. Remove protecting tube 141.
2. Loosen nuts 920, moving them upwards until they are freely exposed.
3. Move the piston actuator into closed position.
4. Position nuts 920 on required travel.
5. Lock nuts 920, tightening them to the tightening torque (⇒ Table 26).
6. Fit protecting tube 141 again.

Table 26: Tightening torque of the closed-position travel stop

Diaphragm diameter (MD) [mm]	[Nm]
30 - 115	25
168 - 202	120

10.4 SK.500/.510 electrical actual-position feedback unit with inductive limit switch

For use with SISTO-C diaphragm valves with pneumatic piston actuator

- SK.500: SISTO-C LAP.520 SF/OF/AZ MD 30 - MD 115
- SK.510: SISTO-C LAP.520 SF/OF/AZ MD 168 - MD 202

Actual-position feedback unit with higher type of protection (enclosure) available on request.

Purpose

Electrical position detection for diaphragm valves with pneumatic piston actuator via limit switches

Mounting

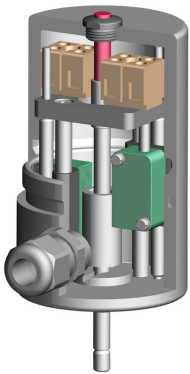

Fig. 44: SK.500/.510 electrical actual-position feedback unit

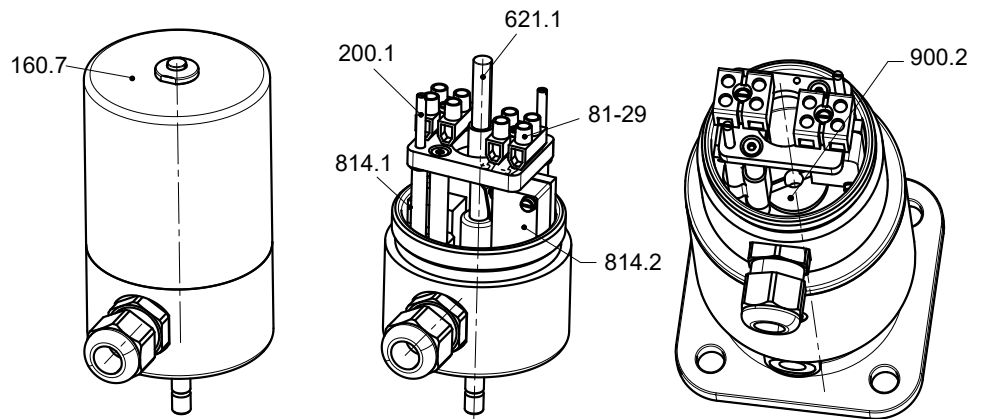

Fig. 45: Mounting and fastening the actual-position feedback unit

Setting the limit switches

To set limit switches 814.1/814.2 observe the functional principle (⇒ Table 28) .

Adjusting the actual-position feedback unit when supplied with the piston actuator:

Adjusting the actual-position feedback unit

1. Unscrew and remove cover 160.7.
2. For the fine adjustment of limit switches 814.1/814.2 turn stem 200.1 with a screwdriver.
3. Screw cover 160.7 back on.
4. Check the switching function.

	<p>NOTE</p>
<p>When ordering an actual-position feedback unit at a later date, indicate the diaphragm valve size and actuator size in the order.</p>	

Retrofitting an actual-position feedback unit with inductive limit switch:

For a correct setting of the accessory the upper section of the diaphragm valve must be mounted on the body as described in the operating manual.

Retrofitting an actual-position feedback unit

1. Remove the plastic cap of the piston actuator with an open-ended spanner (WAF13/WAF21). Unscrew position indicator 621.3 (⇒ Fig. 38) .
2. Unscrew and remove cover 160.7.
3. Undo and remove the fastening screw of terminals 81-29.
4. Remove position indicator 621.1.
5. Adjust distance X of the switching flag of position indicator 621.1 (⇒ Table 27) .
6. Apply one drop of Loctite 243 to the thread of screw 900.2 of the limit switch box. Fasten it to piston actuator 809 and tighten it with a screwdriver.

7. Apply Loctite 243 to the thread of position indicator 621.1. Screw it into the piston rod of piston actuator 809. Loctite 243 thread-locking agent is not included in the scope of supply.
8. Fasten terminals 81-29 with screws again.
9. For the fine adjustment of limit switches 814.1/814.2 turn stem 200.1 with a screwdriver.
10. Screw cover 160.7 back on.
11. Check the switching function.

Factory setting for the limit switches: damped for the entire travel distance, undamped in end position.

Table 27: Setting dimensions of SK.500/.510

Box	MD	Piston actuator [mm]	Dimension X [mm]	Stroke [mm]	Screw 900.2 [mm]
SK.500	30	K35	39	5	M 12 x 1
		K40			
	40	K40	39	7	M 12 x 1
		K50			
	65	K63	39	13	M 12 x 1
		K80			
	92	K80	57	21	M 18 x 1
		K100			
K160		64			
115	K100	57	24	M 18 x 1	
	K160	64			
SK.510	168	K160	92	40	M 18 x 1
		K200			
	202	K200	92	55	M 18 x 1
		KD200			

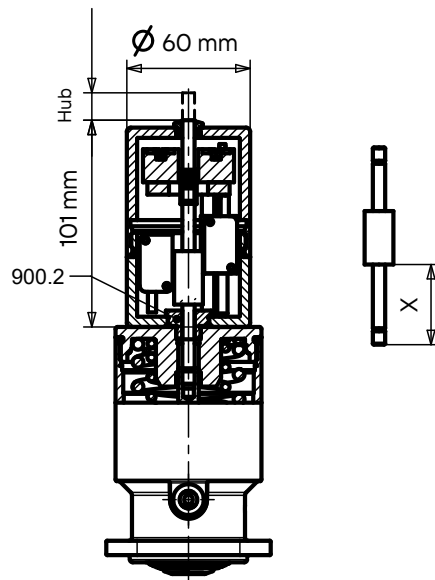

Fig. 46: Mounting of an SK.500/.510

X	Setting dimension at mounting
---	-------------------------------

Table 28: Functional principle of SK.500/510

Limit positions covered / damped	Intermediate positions covered / damped
<p>The diagram shows a vertical shaft with a limit switch on the left and a limit switch on the right. The left switch is labeled 'Limit switch, open' and the right switch is labeled 'Limit switch, closed'. The shaft is shown in two positions: 'Closed' (lower) and 'Open' (higher). Dashed lines indicate the shaft's movement between these positions.</p>	<p>The diagram shows a vertical shaft with a limit switch on the left and a limit switch on the right. The left switch is labeled 'Limit switch, closed' and the right switch is labeled 'Limit switch, open'. The shaft is shown in two positions: 'Closed' (lower) and 'Open' (higher). Dashed lines indicate the shaft's movement between these positions.</p>
Inductive 3-wire system	Inductive 2-wire system

Table 29: Terminal diagram for SK.500/510

<p>The diagram shows two limit switch symbols. The top one is labeled 'Open' and the bottom one 'Closed'. Each switch has three terminals: 1/BN, 4/BK, and 3/BU. The 'Open' switch is connected to terminals 51 L+, 52, and 41 L-. The 'Closed' switch is connected to terminal 42.</p>	<p>The diagram shows two limit switch symbols. The top one is labeled 'Open' and the bottom one 'Closed'. Each switch has two terminals: 1/BN and 2/BU. The 'Open' switch is connected to terminals 51 L+ and 52 L-. The 'Closed' switch is connected to terminals 41 L+ and 42 L-.</p>
Inductive 3-wire system	Inductive 2-wire system

10.5 SK.500/.510 electrical actual-position feedback unit with inductive limit switch and travel stop

For use with SISTO-C diaphragm valves with pneumatic piston actuator

- SK.500: SISTO-C LAP.520 SF/OF/AZ MD 30 - MD 115
- SK.510: SISTO-C LAP.520 SF/OF/AZ MD 168 - MD 202

Purpose

Electrical position detection for diaphragm valves with pneumatic piston actuator via limit switches and open-position travel stop of the actuators

Mounting

For a correct setting of the accessory the upper section of the diaphragm valve must be mounted on the body as described in the operating manual.

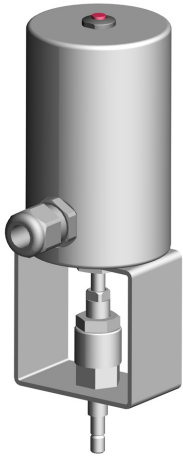

Fig. 47: SK.500/.510 electrical actual-position feedback unit with travel stop

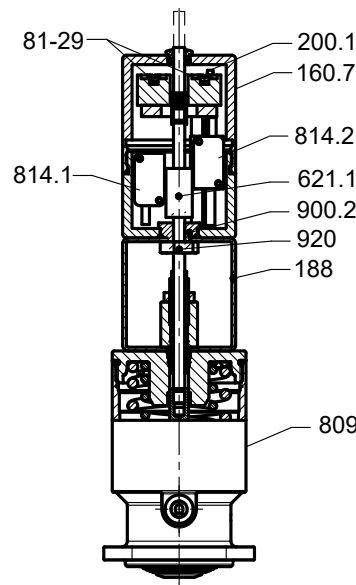

Fig. 48: Mounting of travel stop and actual-position feedback unit

Adjusting the travel stop and actual-position feedback unit when supplied with the piston actuator:

- Set the travel stop (⇒ Section 10.2, Page 51) .
- Adjust the actual-position feedback unit (⇒ Section 10.4, Page 54) .

Retrofitting an actual-position feedback unit with inductive limit switch and travel stop:

Retrofitting an actual-position feedback unit

1. Remove the plastic cap of piston actuator 809 with an open-ended spanner (WAF13/WAF21). Unscrew position indicator 621.3 (⇒ Fig. 38) .
2. Place fixing plate 188 on the diaphragm valve. Screw the travel stop assembly into the thread of the piston actuator. Tighten it to the specified tightening torque (⇒ Table 24) .
3. Set the travel stop (⇒ Section 10.2, Page 51) .
4. Unscrew and remove cover 160.7.
5. Undo and remove the fastening screw of terminals 81-29.
6. Remove position indicator 621.1.
7. Adjust distance X of the switching flag of position indicator 621.1 (⇒ Table 30) .
8. Place the limit switch box on fixing plate 188. Apply one drop of Loctite 243 to the thread of screw 900.2 and tighten it with a screwdriver.

9. Apply Loctite 243 to the thread of position indicator 621.1. Screw it into the piston rod of piston actuator 809. Loctite 243 thread-locking agent is not included in the scope of supply.
10. Fasten terminals 81-29 with screws again.
11. For the fine adjustment of limit switches 814.1/814.2 turn threaded stem 200.1 with a screwdriver.
12. Screw cover 160.7 back on.
13. Check the switching function.

	NOTE
	Optionally for diaphragm valve sizes MD 168-MD 202/SK.510 the supplied eyebolts can be used for lifting.

Table 30: Setting dimensions of SK.500/510 and travel stop

Box	MD	Piston actuator [mm]	Dimension X [mm]	Stroke [mm]	Screw 900.2 [mm]
SK.500	30	K35	99	5	M 12 x 1
		K40			
	40	K40	99	5	M 12 x 1
		K50			
	65	K63	99	13	M 12 x 1
		K80			
	92	K80	117	21	M 18 x 1
		K100	124		
K160					
115	K100	117	24	M 18 x 1	
	K160	194			
SK.510	168	K160	192	45	M 18 x 1
		K200			
	202	K200	192	60	M 18 x 1
		KD200			

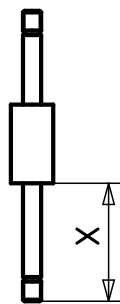

Fig. 49: Setting dimension X at mounting

Table 31: Terminal diagram for SK.500/.510

<p>Open</p> <p>Closed</p>	<p>Open</p> <p>Closed</p>
<p>Inductive</p>	<p>Inductive</p>
<p>3-wire system</p>	<p>2-wire system</p>

10.6 SK.500/.510 electrical actual-position feedback unit with mechanical limit switch

For use with SISTO-C diaphragm valves with pneumatic piston actuator

- SK.500: SISTO-C LAP.520 SF/OF/AZ MD 40 - MD 115
- SK.510: SISTO-C LAP.520 SF/OF/AZ MD 168 - MD 202

Purpose

Electrical position detection for diaphragm valves with pneumatic piston actuator via mechanical limit switches

	NOTE
<p>For retrofitting an actual-position feedback unit indicate the valve size and actuator size in the order. The 3 position indicator units are adjusted to the diaphragm valve sizes (⇒ Fig. 50) .</p>	

Mounting

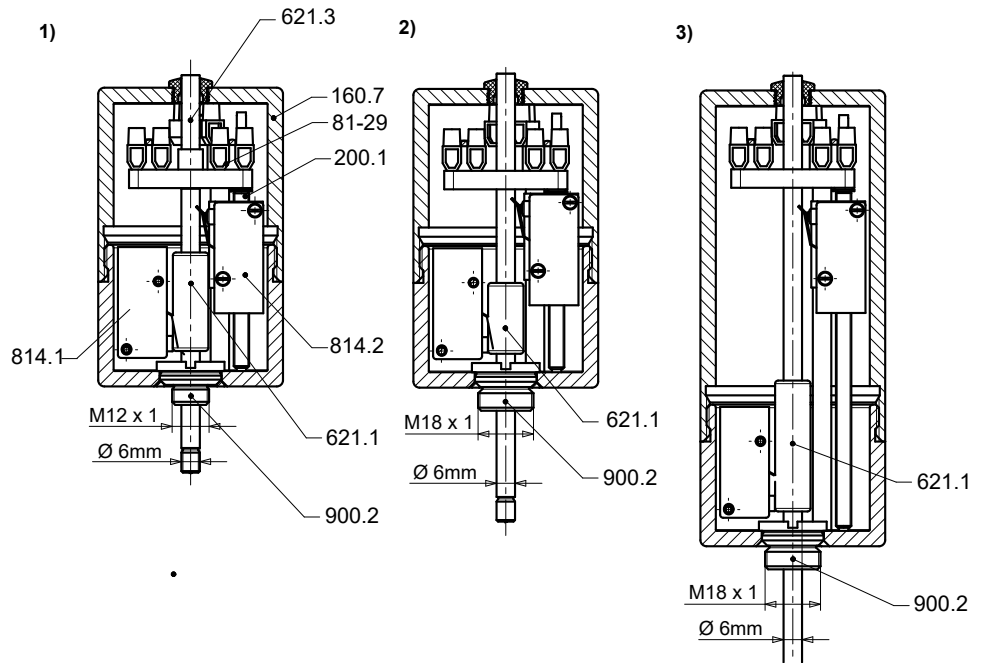

Fig. 50: Overview of SK.500/.510 actual-position feedback units with mechanical limit switch

1	SK.500 (MD 30-65)	2	SK.500 (MD 92-115)	3	SK.510 (MD 168-202)
---	-------------------	---	--------------------	---	---------------------

Adjusting the actual-position feedback unit when supplied with the piston actuator:

Adjusting the actual-position feedback unit

1. Unscrew and remove cover 160.7.
2. For the fine adjustment of limit switches 814.1/814.2 turn stem 200.1 with a screwdriver.
3. Screw cover 160.7 back on.
4. Check the switching function.

Retrofitting an actual-position feedback unit with mechanical limit switch:

Retrofitting an actual-position feedback unit

For a correct setting of the accessory the upper section of diaphragm valve must be mounted on the body as described in the operating manual.

1. Remove the plastic cap of the piston actuator with an open-ended spanner (WAF13/WAF21). Unscrew and remove position indicator 621.3.
2. Unscrew and remove cover 160.7.

3. Undo and remove the fastening screw of terminals 81-29.
4. Remove position indicator 621.1.
5. Apply one drop of Loctite 243 to the thread of screw 900.2 of the limit switch box. Fasten it to the piston actuator and tighten it with a screwdriver.
6. Apply Loctite 243 to the thread of position indicator 621.1. Screw it into the piston rod of piston actuator 809. Loctite 243 thread-locking agent is not included in the scope of supply.
7. Fasten terminals 81-29 with screws again.
8. For the fine adjustment of limit switches 814.1/814.2 turn stem 200.1 with a screwdriver.
9. Screw cover 160.7 back on.
10. Check the switching function.

Table 32: Terminal diagram for SK.500/.510

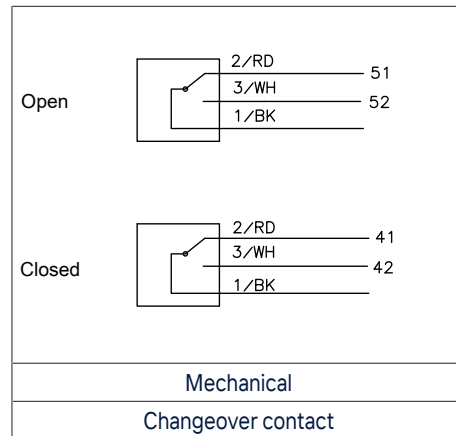

10.7 Directly mounted inductive actual-position feedback unit for open position

For use with SISTO-C diaphragm valves with pneumatic piston actuator

- SISTO-C LAP.520 SF/OF/AZ MD 30 - MD 202

Purpose

Actual-position feedback unit for diaphragm valves with pneumatic piston actuator

Table 33: Inductive actual-position feedback unit

Limit switch 814	MD	Piston actuator [mm]	Connection thread [mm]	Screw 900	Adapter 825
SK.500	30	K35	M 12 x 1	X	-
		K40			
	40	K40			
		K50			
	65	K63			
	SK.510	65			
92		K80			
		K100			
		K160			
115		K100			
SK.510	115	K160	-	-	-
	168	K160			
		K200			
	202	K200			
KD200					

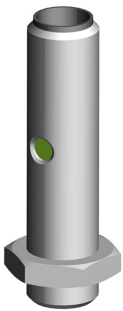

Fig. 51: Directly-mounted actual-position feedback unit

Mounting

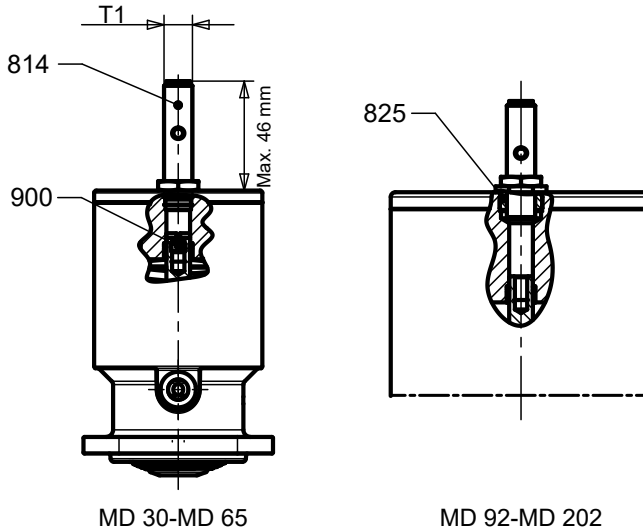

Fig. 52: Mounting of inductive actual-position feedback unit

Retrofitting the inductive actual-position feedback unit:

Retrofitting the inductive actual-position feedback unit

1. Remove the plastic cap of the piston actuator with an open-ended spanner (WAF13/WAF21). Unscrew and remove position indicator 621.3 (⇒ Fig. 38) .
2. Depending on function SF/OF/AZ: Move the piston actuator into open position.
3. For piston actuators with M12x1 connection thread, fit screw 900 in the piston rod and tighten it.

4. For piston actuators with M18x1 connection thread, screw adapter 825 into the piston actuator and tighten it with an open-end spanner (WAF19).
5. Screw inductive limit switch 814 into the connection thread up to screw 900 or up to the piston rod.
6. Back limit switch 814 off one turn. Verify that the LED of the limit switch is lit.
7. Tighten the fastening nut of limit switch 814 (WAF17).
8. Check the switching function again as necessary.

10.8 LAP.525 two-stage actuator

For use with SISTO-C diaphragm valves with pneumatic piston actuator

- SISTO-C LAP.525 MD 40 K50
- SISTO-C LAP.525 MD 65 K80
- SISTO-C LAP.525 MD 92-MD 115 K100

Purpose

Diaphragm valves with pneumatic piston actuator with 2 separate stroke ranges

Table 34: Technical data

MD	Piston actuator [mm]	Fp ⁴⁶⁾ [N]	F1 (SF) ⁴⁷⁾ [N]	F2 (SF) ⁴⁸⁾ [N]	Weight [kg]
40	K50	1037	753	941	3
65	K80	2654	2110	2313	8
92	K100	4209	3180	3637	12
115	K100	4209	3180	3723	12,7

Table 35: Dimensions

MD	Piston actuator [mm]	SK-Box	Height incl. stroke [mm]	D [mm]	B [mm]	Stroke [mm]	Air port (G)
40	K50	SK.500	330	60	55	7	M5
65	K80	SK.500	450	89	80	13	G 1/8
92	K100	SK.500	505	110	105	21	G 1/8
115	K100	SK.500	500	110	125	24	G 1/8



Fig. 53: LAP.525 two-stage actuator

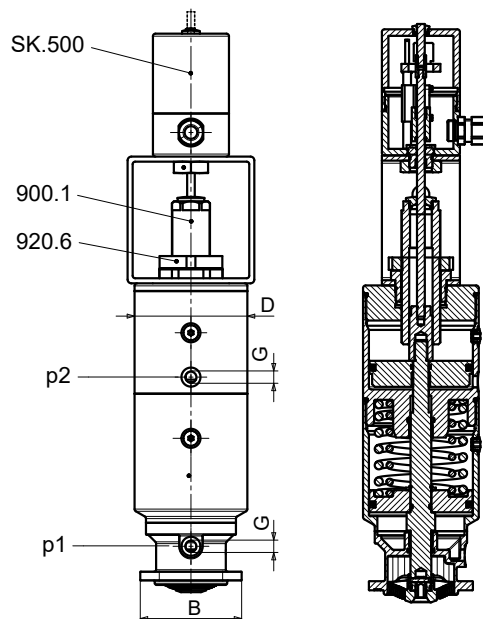

Fig. 54: Two-stage actuator

- 46** Pressure force at 5.5 bar operating pressure
- 47** Closing force
- 48** Spring force in opening direction

Function of the piston actuator, control pressure p1

- When control pressure p1 is applied, the piston actuator moves the full stroke in opening direction.
- When the pressure drops, the piston actuator moves into the closed position (fail-safe position).

Function of the piston actuator, control pressure p2

- When control pressure p2 is applied, the piston actuator moves the set partial stroke in opening direction.
- When the pressure drops, the piston actuator moves into the closed position (fail-safe position).

Function of SK.500

- The lower limit switch detects the closed position of piston actuator stroke 1 (p1) (default setting).
- The limit position of the upper limit switch can either be set to the open position of piston actuator 1 (p1) or to the open position of the limited partial stroke of piston actuator 2 (p2) (default setting).

Setting the stroke:

1. Operate piston actuator 1 (p1).
2. Undo nut 920.6 with a C-spanner to DIN 1810, type A, 45 - 50 mm.
3. Set the required partial stroke with screw 900.1.
4. Tighten nut 920.6.
5. The upper limit switch can be set to open position for piston actuator 1 or piston actuator 2 (⇒ Section 10.4, Page 54) .

10.9 Samson 3730-X electro-pneumatic positioner

For use with SISTO-C diaphragm valves with pneumatic piston actuator

- SISTO-C LAP.520 SF/OF/AZ MD 30 - MD 168

Purpose

Positioner for diaphragm valves with pneumatic piston actuator

	NOTE
	Observe the positioner manufacturer's operating manual included with the supply.

Mounting

Table 36: Interface of the positioner

Screw 900.2 [mm]	Diaphragm diameter (MD)	Piston actuator 809 [mm]
Connection M 12 x 1	30	K35
		K40
	40	K40
		K50
65	K63	
	Connection M 18 x 1	92
K100		
115		K100
		K160
168	K160	
	K200	

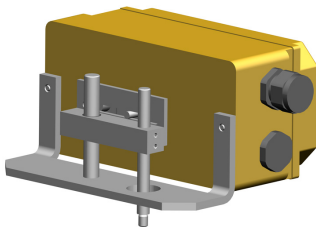

Fig. 55: Electro-pneumatic positioner

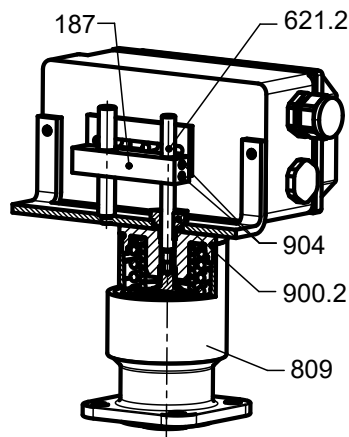

Fig. 56: Mounting of the positioner

Adjusting the positioner when supplied with the pneumatic piston actuator:

Adjusting the positioner

For a correct setting of the positioner the upper section of the diaphragm valve must be mounted on the body as described in the operating manual.

1. Adjust bracket 187 so that the lever of the positioner is in a horizontal position at half the stroke distance.
2. Re-tighten grub screws 904 with an Allen key (WAF2.5).
3. Check the switching function.

Retrofitting the positioner

Retrofitting the positioner

1. Remove the plastic cap of piston actuator 809 with an open-ended spanner (WAF13/ WAF21). Unscrew position indicator 621.3 of the piston actuator (⇒ Fig. 38) .

2. Fasten the positioner to the piston actuator with screw 900.2 (WAF22).
3. Undo grub screws 904 with an Allen key (WAF2.5).
4. Apply a drop of Loctite 243 to the thread of position indicator 621.2. Screw it into the piston rod of piston actuator 809. Loctite 243 thread-locking agent is not included in the scope of supply.

10.10 Inductive actual-position feedback unit for open position and/or closed position

For use with SISTO-C diaphragm valves with pneumatic piston actuator

- SISTO-C LAP.520 SF/OF/AZ MD 30 - MD 202

Purpose

Actual-position feedback unit for diaphragm valves with pneumatic piston actuator. Sensor M 12 x 1 for all sizes.

Mounting

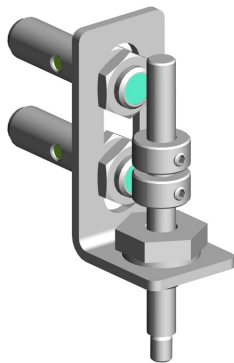

Fig. 57: Actual-position feedback unit with limit switch

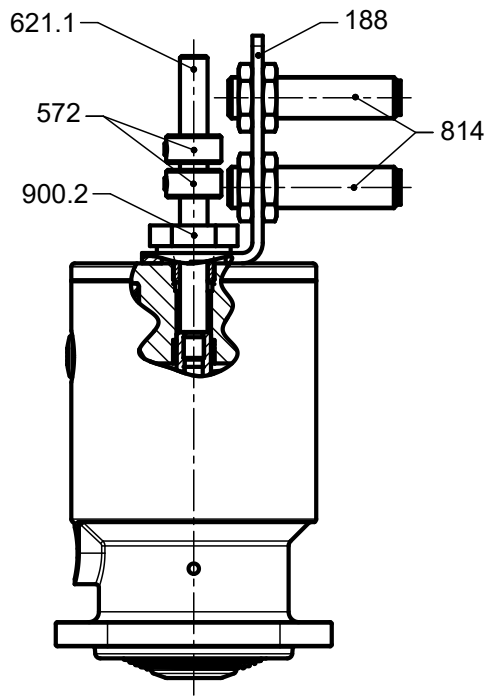

Fig. 58: Mounting of inductive actual-position feedback unit

Setting the limit switches:

Setting the limit switches

1. Undo the grub screw of contact pieces 572 with an Allen key (WAF2.5).
2. Set contact pieces 572 to closed position and/or open position. The sensor reacts when the green LED at the sensor lights up.
3. The distance between limit switches 814 and contact pieces 572 may have to be adjusted. This can be done by using the fastening nut of the sensors (M 12 x 1 = WAF17/M 18 x 1 = WAF24).
4. Check the switching function.

Retrofitting the actual-position feedback unit:

Retrofitting the actual-position feedback unit

1. Remove the plastic cap of the piston actuator with an open-ended spanner (WAF13/WAF21). Unscrew and remove position indicator 621.3 (⇒ Fig. 38) .
2. Apply Loctite 243 to the thread of position indicator 621.1. Screw it into the piston rod of the piston actuator. Loctite 243 thread-locking agent is not included in the scope of supply.
3. Place fixing plate 188 with limit switch 814 on the diaphragm valve with piston actuator. Fasten it with screw 900.2 (WAF22).

11 Setting and Using Variants for SISTO-C Diaphragm Valves

11.1 Mechanical closed-position and open-position travel stop

For use with SISTO-C diaphragm valves

- SISTO-C HV.523 MD 168-MD 202

Purpose

Closed-position and open-position travel stop for diaphragm valves

Mounting

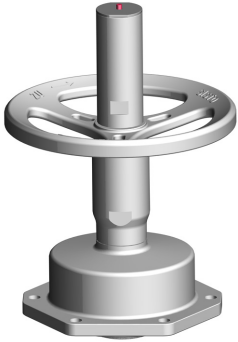

Fig. 59: Open-position

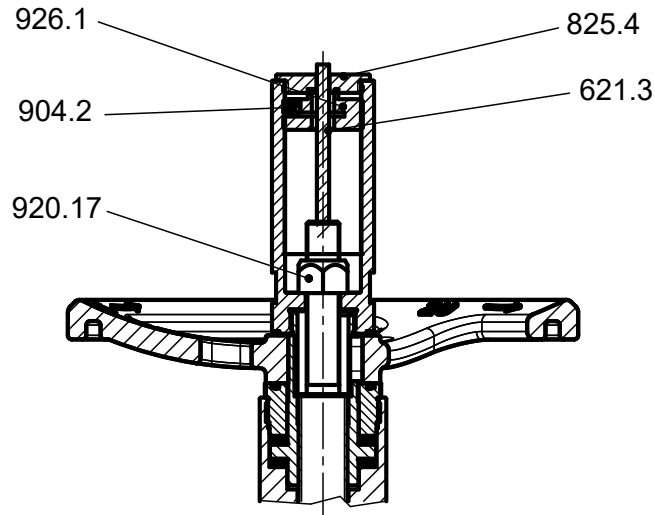

Fig. 60: Closed-position and open-position travel stop MD 168-MD 202

Setting the closed-position travel stop:

Setting the closed-position travel stop

For a correct setting of the travel stop the upper section of the diaphragm valve must be mounted on the body as described in the operating manual.

1. Screw on adapter cover 825.4 with an open-ended spanner (WAF46).
2. Undo grub screw 904.2 with an Allen key (WAF3).
3. Unscrew position indicator 621.3 as required.
4. Unscrew prevailing torque nut 926.1 with a socket wrench (WAF15).
5. Adjust nut 920.17 (WAF24), e.g. with a socket wrench (21 x 24 DIN 896 B), to set the travel as required.

Setting the open-position travel stop:

Setting the open-position travel stop

For a correct setting of the travel stop the upper section of the diaphragm valve must be mounted on the body as described in the operating manual.

1. Screw on adapter cover 825.4 with an open-ended spanner (WAF46).
2. Adjust prevailing torque nut 926.1 with a socket wrench (WAF15) and set the travel as required.
3. Tighten grub screw 904.2 with the Allen key (WAF3) to firmly fasten prevailing torque nut 926.1.
4. Screw in adapter cover 825.4. Tighten it with an open-ended spanner (WAF46).

11.2 Upper section of the diaphragm valve with handwheel locking device and padlock

For use with SISTO-C diaphragm valves

- SISTO-C HV.514/.524 MD 40 - MD 115
- SISTO-C HV.524 MD 168-202 (available on request)

Purpose

Handwheel locking device including padlock for diaphragm valves

Mounting



Fig. 61: Upper section of the diaphragm valve with handwheel locking device and padlock

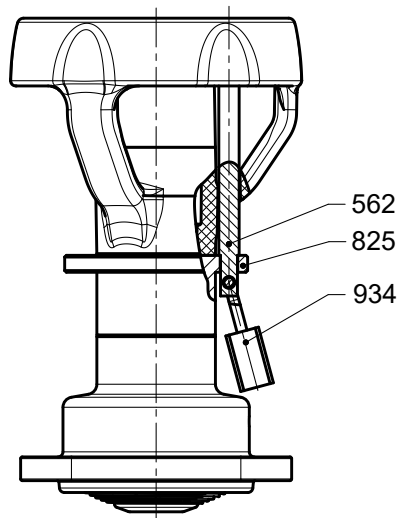

Fig. 62: Upper section of the diaphragm valve with handwheel locking device and padlock MD 40 - MD 115

Fitting the locking device

1. Remove padlock 934 and parallel pin 562.
2. Set the diaphragm valve to the required position.
3. Then insert parallel pin 562 into the hole of handwheel and adapter 825.
4. Feed padlock 934 through the radial bore of parallel pin 562 and lock it.

11.3 Upper section of the diaphragm valve with stainless steel handwheel and stem extension

For use with SISTO-C diaphragm valves

- SISTO-C HV.516/.526 MD 40 - MD 115
- MD 30 on request

Purpose

Diaphragm valve with stem extension. (Handwheel arranged higher in relation to the piping).

Mounting

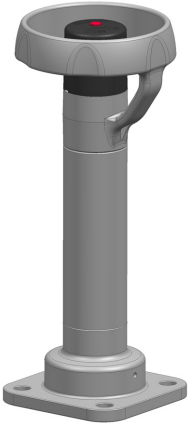

Fig. 63: Upper section of the diaphragm valve with stainless steel handwheel and stem extension

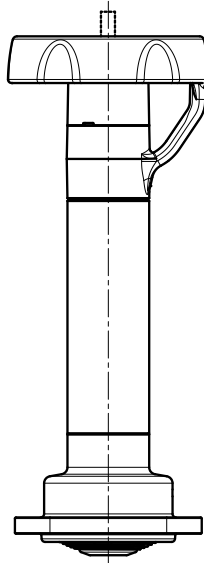

Fig. 64: Upper section of the diaphragm valve with stem extension

Function

Function see "Function of diaphragm valve with handwheel" (⇒ Section 4.3.4, Page 21) .

11.4 Upper section of the diaphragm valve with handwheel and limit switches

For use with SISTO-C diaphragm valves

- SISTO-C HV.518/.528 MD 40-MD 115
- SISTO-C HV.528 MD 168

Purpose

Diaphragm valve with position detection by inductive closed-position and open-position limit switches

Mounting



Fig. 65: Upper section of the diaphragm valve with limit switches

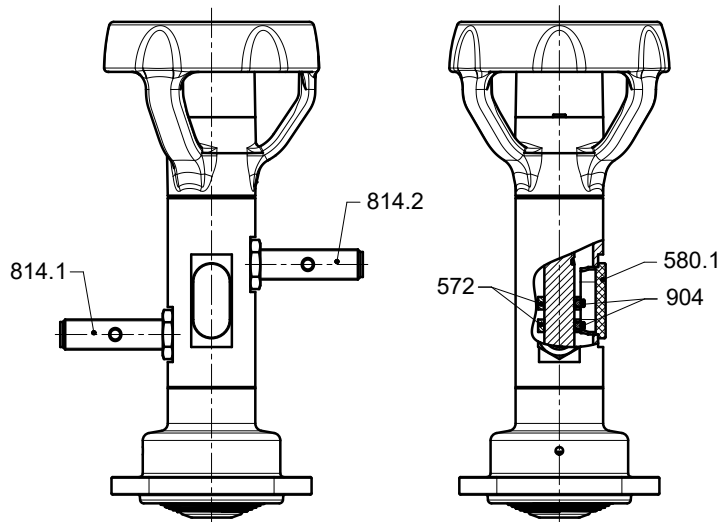

Fig. 66: Upper section of the diaphragm valve with limit switches

Setting the limit switches:

Setting the limit switches Limit switches 814.1/814.2 are supplied set to closed position and open position. Should this setting need to be changed:

1. For a correct setting of the limit switches the upper section of the diaphragm valve must be mounted on the body as described in the operating manual.
2. Remove cap 580.1.
3. Undo grub screw 904 and position contact pieces 572 as required.
4. Tighten grub screw 904 again.
5. Check the limit switch function.

11.5 Upper section of the diaphragm valve with handwheel and pneumatic fail-safe action

For use with SISTO-C diaphragm valves

- SISTO-C HV.519/.529 MD 40 - MD 92

Purpose

The diaphragm valve can be actuated when the pneumatic piston actuator is activated (pneumatic release).

Mounting

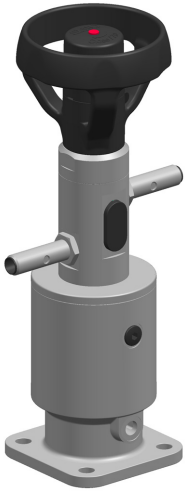

Fig. 67: Upper section of the diaphragm valve with fail-safe action

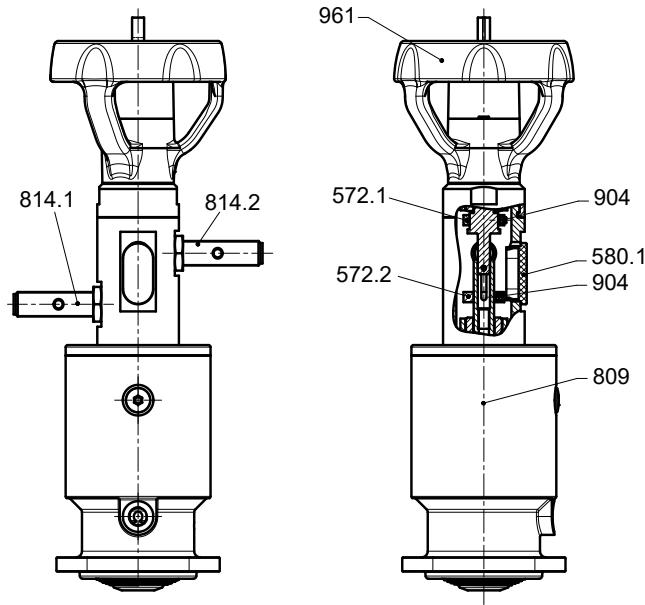

Fig. 68: Upper section of the diaphragm valve with pneumatic fail-safe action

Function

- If the control pressure of the piston actuator is interrupted, the actuator moves to the closed position = fail-safe position.
- Lower limit switch 814.1 signals this position of piston actuator 809.
- To release the valve from fail-safe position, handwheel 961 has to be moved to closed position.
- Upper limit switch 814.2 signals the closed position.
- Apply pressure to the piston actuator.
- Then slowly open the diaphragm valve again with handwheel 961.
- The two limit switches are supplied set as follows:
Lower limit switch 814.1: Closed position of piston actuator 809.
Upper limit switch 814.2: Closed position of the handwheel.

Adjusting the limit switch settings:

Adjusting the limit switch settings

1. Remove cap 580.1.
2. Undo grub screw 904 with an Allen key.
3. Position contact pieces 572.1 or 572.2 as required.
4. Tighten grub screw 904 again.

12 EU Declaration of Conformity of SISTO-C/-B

Hereby we,

SISTO Armaturen S.A.
18, rue Martin Maas
6468 Echternach (Luxembourg)declare that **the product:****Diaphragm valves and
Diaphragm valves with pneumatic piston actuator**

SISTO-C	PN 16	DN 32 - 300
SISTO-B	PN 10	DN 32 - 100

satisfies the safety requirements laid down in the European Pressure Equipment Directive 2014/68/EU.

Suitable for:

Fluids in Groups 1 and 2

Conformity assessment procedure:

Module H

Name and address of the notified body responsible for approval and surveillance:TÜV Rheinland Industrie Service GmbH
Zertifizierungsstelle für Druckgeräte
Am Grauen Stein
51105 Köln (Germany)**Identification number of the notified body:**

0035

Valves \leq DN 25 comply with the European Pressure Equipment Directive 2014/68/EU, Article 4, Section 3. They must bear neither the CE marking nor the identification number of a notified body.

The EU Declaration of Conformity was issued in/on:

Echternach, 25 November 2024

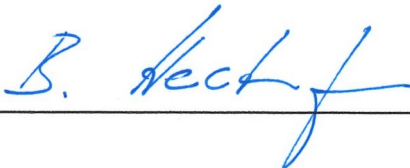

Bernd Hackenberger
Head of Design and Development

Markus Schuster
Head of Integrated Management Systems

Index**A**

Actuation/operation 26

C

Commissioning/start-up 26

D

Design 18

Disposal 14

Drive 20

E

Event of damage 6

Explosion protection 11

F

Faults

Causes and remedies 37

Function 21

Functional test 26

I

Installation position 23

Insulation 25

Intended use 9

K

Key to safety symbols/markings 7

L

Leak test 26

M

Maintenance 31

Materials 39

O

Operating data

SISTO-C LAP actuated valve 18

SISTO-C manually operated valve 18

Operating limits 9

Other applicable documents 6

P

Piping 24

Pressure/temperature ratings 30

R

Replacing the diaphragm
SISTO-C 34

Return to supplier 14

S

Safety 8

Safety awareness 10

Shutdown 30

Storage 14

T

Tightening torques

SISTO-B 36

SISTO-C 36

Transport 13

W

Warnings 7

Warranty claims 6



SISTO Armaturen S.A.

18, rue Martin Maas • L-6468 Echternach

www.sisto-aseptic.com

A KSB Company •  **KSB**

0570.822/05-EN