

Intelligent Actual-position Feedback Unit

SISTO-SK-i LED

For Valves with Linear Actuators
Stroke: 5 - 45 mm

Type Series Booklet



Legal information/Copyright

Type Series Booklet SISTO-SK-i LED

All rights reserved. The contents provided herein must neither be distributed, copied, reproduced, edited or processed for any other purpose, nor otherwise transmitted, published or made available to a third party without the manufacturer's express written consent.

Subject to technical modification without prior notice.

© SISTO Armaturen S.A., Echternach, Luxemburg 08/01/2021

Contents

Intelligent Actual-position Feedback Unit 4

 Intelligent Actual-position Feedback Unit for Linear Valves..... 4

 SISTO-SK-i LED 4

 Product description of SISTO-SK-i LED 4

 Main applications..... 4

 Operating data..... 4

 Materials..... 4

 Design details 4

 Product benefits..... 4

 Related documents 4

 Purchase order specifications 4

 Technical data of SISTO-SK-i LED 6

 Indicator and operating elements of SISTO-SK-i LED 6

 Connector pin assignment of SISTO-SK-i LED 24V 6

 Pneumatic connection 6

 Additional technical data of SISTO-SK-i LED with solenoid valve..... 7

 Technical data of SISTO-SK-i LED AS-i..... 8

 Indicator and operating elements of SISTO-SK-i LED AS-i..... 8

 Connector pin assignment of SISTO-SK-i LED AS-i 8

 Pneumatic connection 8

 Additional technical data of SISTO-SK-i LED AS-i with solenoid valve 9

 Dimensions and weights..... 10

 Mechanical data 10

 Accessories SISTO-SK-i LED..... 11

Intelligent Actual-position Feedback Unit

Intelligent Actual-position Feedback Unit for Linear Valves

SISTO-SK-i LED



Product description of SISTO-SK-i LED

SISTO-SK-i LED is an intelligent actual-position feedback unit for linear valves. Valve position is indicated visually and clearly by means of coloured high-visibility LEDs. User-friendly setting of limit positions by automatic initialisation in situ or via the process control system.

SISTO-SK-i LED continuously records valve travel and comprises a microcontroller-based analysing unit. Valve position is signalled visually by the device's high-visibility LEDs and electrically via digital outputs.

SISTO-SK-i LED is connected via an M12 connector. It is ready for operation as soon as initialisation is complete.

Main applications

- Biotechnology
- Chemical industry/Fine chemicals
- Food industry / beverage industry
- Pharmaceutical industry
- Process industry

Operating data

Operating properties

Characteristic	Value
Stroke [mm]	5 - 45
Min. permissible temperature [°C]	≥ -30
Max. permissible temperature [°C]	≤ +60

Materials

Overview of available materials

Description	Material	Material number
Lower housing section	Plastic, black	PA66-GF30
Lower housing section	X2CrNiMo17-12-2	1.4404
Housing cover	Plastic, transparent	PA6
Electrical connection	X2CrNiMo17-12-2	1.4404

Design details

- Binary fault output
- Electrical connection via M12 plug
- Compact actual-position feedback unit for mounting on linear valves
- Continuous valve travel recording via microcontroller
- Open/closed position feedback
- Status indication and position indication via high-visibility LEDs

Directives

EMC Directive	2014/30/EU
RoHS Directive	2011/65/EU
Machinery Directive	2006/42/EC

Standards

Enclosure to EN 60529	IP65
Safety class to EN 61140	Safety class III

Variants

- Connection via AS interface
- Stainless steel housing (1.4404)
- Integrated 3/2-way solenoid valve (actuator types SF and OF)

Product benefits

- Easy on-site initialisation by magnet
- Remote initialising possible
- Optional AS-i field bus connection
- Smooth, easy-to-clean surfaces

Related documents

Information/documents

Document	Reference number
Operating manual SISTO-SK-i LED/SK-i LED AS-i	8676.81

Purchase order specifications

Please specify the following information in all enquiries or purchase orders:

Designs

Order code	Design
S1	Actual-position feedback unit 24 V LED
S6	Actual-position feedback unit 24 V LED with solenoid valve
A1	Actual-position feedback unit LED AS-i
A6	Actual-position feedback unit LED AS-i with solenoid valve

Overview of available materials

Order code	Material	Material number
K0	Plastic	PA66-GF30
00	Stainless steel X2CrNiMo17-12-2	1.4404

Mounting

Order code	Mounting on	Diaphragm diameter [MD]
01	SISTO-C LAP.520	30 - 65
02	SISTO-C LAP.520	92 - 115
03	SISTO-C LAP.520/.530	168

Ordering example SK-i LED: S1/K0/02

- 1. Design: actual-position feedback unit 24 V LED
- 2. Material: PA66-GF30
- 3. SISTO-C LAP.520 MD 92 - 115

Technical data of SISTO-SK-i LED

Electrical data of SISTO-SK-i LED 24 V

Characteristic	Value
Electrical connection	8-pin M12 round plug connector
Supply voltage [V]	24 +/- 10 %
Current input [mA]	Approx. 45
Duty ratio	100 %
Digital outputs	24 V, max. 100 mA, short-circuit-proof Open Closed Fault
Digital inputs	24 V, Low: 0 - 3 V, High: 18 - 24 V Remote initialisation

Indicator and operating elements of SISTO-SK-i LED



1)	Magnetic sensor	2)	High-visibility LED
----	-----------------	----	---------------------

Colour code of high-visibility LED

Colour code of high-visibility LED	Operating status
Orange	Valve in open position
Green	Valve in closed position
Red	Fault
Yellow	Initialising
Blue	Not initialised

Connector pin assignment of SISTO-SK-i LED 24V

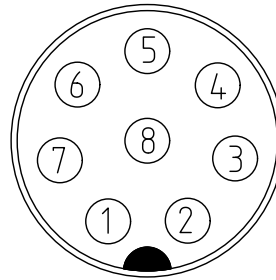

Pin assignment

Pin	Assignment
1	+ 24 V
2	DO Open ¹⁾
3	0 V
4	DO Closed ¹⁾
5	DI Teach-in ²⁾
6	DI Solenoid valve ²⁾³⁾
7	DO Fault ¹⁾
8	Not used

Pneumatic connection

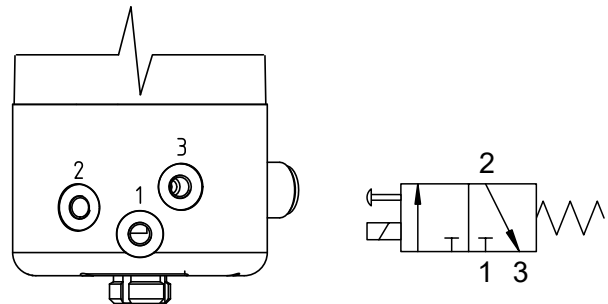

Assignment of threaded ports

Threaded port	Assignment
1	Air supply
2	Actuator
3	Air outlet

1 Binary output
2 Binary input
3 With integrated solenoid valve only

Additional technical data of SISTO-SK-i LED with solenoid valve

Electrical data

Characteristic	Value
Current input [mA]	Approx. 90
Additional digital input	Solenoid valve

Pneumatic data

Characteristic	Value
Threaded port	Internal thread M5
Flow rate [l_w /min.]	15
P max. [bar]	10
Compressed air quality	ISO 8573-1 3/3/3

Materials

Description	Material	Material number
Pneumatic connection	X2CrNiMo17-12-2	1.4404

Technical data of SISTO-SK-i LED AS-i

Electrical data of SISTO-SK-i LED AS-i

Characteristic	Value
Electrical connection	5-pin M12 round plug connector
Supply voltage [V]	26,5 - 31,6
Current input [mA]	Approx. 85
Duty ratio	100 %
AS-i specification	V3.0

AS interface profile

Feature	Value
I/O configuration	7
ID code	A
ID1 code	*
ID2 code	E

Indicator and operating elements of SISTO-SK-i LED AS-i

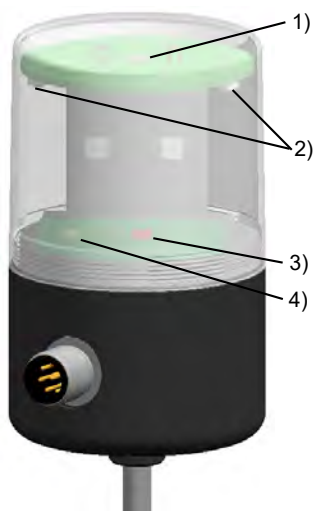

1)	Magnetic sensor	2)	High-visibility LED
3)	AS-i Fault	4)	AS-i Power

Colour code of high-visibility LED

Colour code of high-visibility LED	Operating status
Orange	Valve in open position
Green	Valve in closed position
Red	Fault
Yellow	Initialising
Blue	Not initialised

Colour code of LED

Colour code of LED	Operating status
Green	AS-i Power
Red	AS-i Fault

Connector pin assignment of SISTO-SK-i LED AS-i

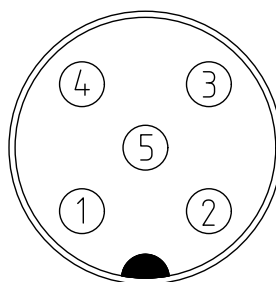

Pin assignment

Pin	Assignment
1	AS-i +
2	Not used
3	AS-i -
4	Not used
5	Not used

Pneumatic connection

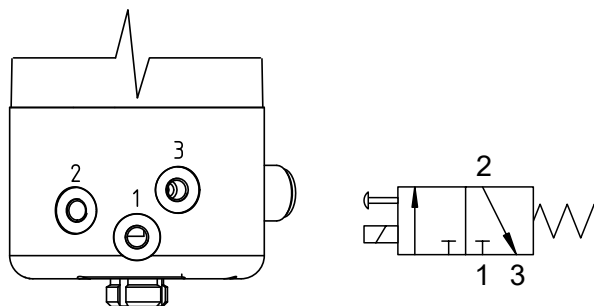

Assignment of threaded ports

Threaded port	Assignment
1	Air supply
2	Actuator
3	Air outlet

Additional technical data of SISTO-SK-i LED AS-i with solenoid valve

Electrical data

Characteristic	Value
Current input [mA]	Approx. 135

Pneumatic data

Characteristic	Value
Threaded port	Internal thread M5
Flow rate [l _w /min.]	15
P max. [bar]	10
Compressed air quality	ISO 8573-1 3/3/3

Materials

Description	Material	Material number
Pneumatic connection	X2CrNiMo17-12-2	1.4404

Inputs of SISTO SK-i LED AS-i (AS-i master perspective)

Bit	Function	Logic
DI0	OPEN position	0 = "Not open" position 1 = "Open" position
DI1	CLOSED position	0 = "Not closed" position 1 = "Closed" position
DI2	Ready	0 = Normal operation 1 = Initialisation mode
DI3	Fault	0 = Normal operation 1 = Fault Alternating at 1 Hz = valve not initialised

Outputs of SISTO SK-i LED AS-i (AS-i master perspective)

Bit	Function	Logic
DO0	Operate valve	0 = Pilot valve not operated (if fitted) 1 = Pilot valve operated
DO1	Not connected	-
DO2	Activate teach-in	0 = Normal operation 1 = Initialisation mode
DO3	Not connected	-

Dimensions and weights

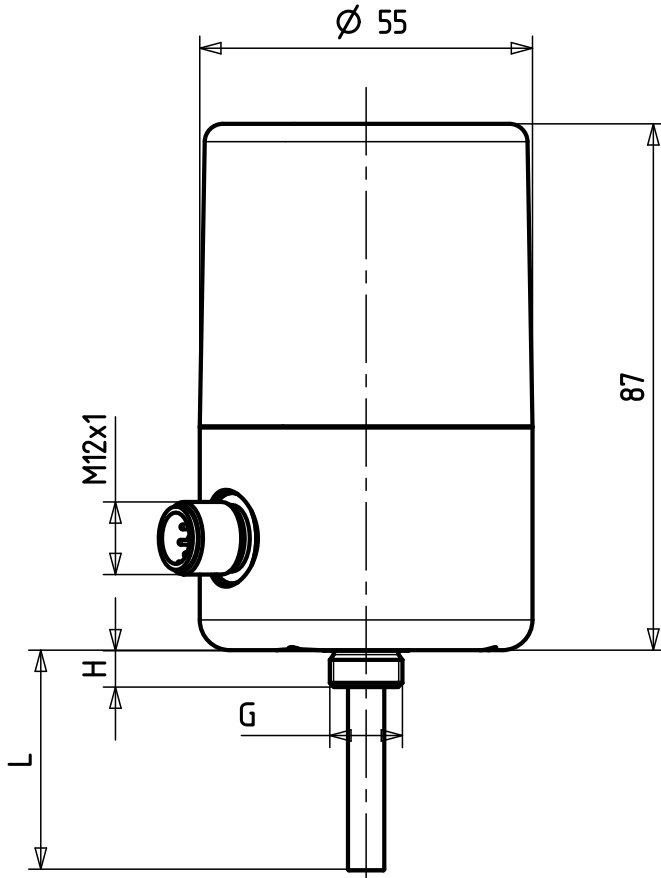

SISTO-C LAP.520

Mechanical data

Dimensions table of SISTO-SK-i LED/SK-i LED AS-i

Dimensions	[mm]
Diameter	55
Height	87
Stroke	5 - 45

Weights

Material	Material number	Weight [kg]
Plastic, black	PA66-GF30	0,170
X2CrNiMo17-12-2	1.4404	0,380

Linear valves, variants for actuator SISTO-C LAP.520/.530⁴⁾

Ordering code for mounting options	01	02	03
L [mm]	38	38	59
G	M12 x 1	M18 x 1	M18 x 1
H [mm]	6	6	8
Diaphragm diameter (MD)	30 - 65	92 - 115	168

⁴ Further mounting variants available on request

Accessories SISTO-SK-i LED**Set comprising programming magnet, wire pin and lanyard**

1)	Lanyard	2)	Programming magnet	3)	Wire pin
----	---------	----	--------------------	----	----------



SISTO Armaturen S.A.
18, rue Martin Maas • L-6468 Echternach
Tel.: +352 325085-1 • Fax: +352 328956
E-Mail: info@sisto-aseptic.com
www.sisto-aseptic.com

A KSB Company • The KSB logo, consisting of the letters "KSB" in a bold, blue, sans-serif font, followed by a stylized blue square icon containing a white lowercase letter "b".